



TM

# DITEQ

DIAMOND TOOLS & EQUIPMENT

## DITEQ CORPORATION 2014 PRICE CATALOG



1250 NW MAIN • LEE'S SUMMIT, MO 64086  
PHONE 866-688-1032 • FAX 877-220-4777



**DITEQ** has some of the world's most innovative metallurgical engineering with our **ARIX** technology, introduced several years ago. This amazing technology allows for precise diamond arrangement and alignment throughout each blade segment, set to control wear and make the blade cut faster. In some situations, this technology can increase the cutting speed by 50% while doubling a normal blades life. DITEQ is the only company that employs full ARIX technology throughout the segment.

DITEQ continues to increase the number and types of products utilizing ARIX technology which now includes the Generation 3 ARIX product. You can find ARIX technology in products ranging from wall saw blades, flat saw blades, diamond wire to core bits.

*Discover the DITEQ*  
**Difference!**

## Content

- 3 Professional Diamond Blades for Flat Saws
- 9 Diamond Blades for Soff-Cut® Saws
- 10 Diamond Blades for Ring Saws, Wall Saws
- 11 Diamond Chain / Wire
- 12 Diamond Core Drill Bits
- 15 SHIBUYA Core Drill Machines
- 23 General Purpose Diamond Blades for High Speed and Small Flat Saws
- 26 Slurry Control / Cleaners
- 26 Abrasives
- 27 Diamond Cup Grinding Wheels
- 28 Dust Control and Industrial Vacuums
- 31 Crack Chasing Saws and Blades
- 32 Floor Grinders and Surface Prep Tooling
- 40 Masonry Saws and Diamond Blades
- 42 Tuck Pointing Blades
- 43 Stone Diamond Blades and Fabrication Tools
- 46 Terms and Conditions / Warranty
- 47 Cutting Speeds and Depths

The following discount codes are found on each product chart:

**Diamonds    Abrasives/Chemicals    Equipment    Parts**

**D**

**A**

**E**

**P**

## THREE GENERATIONS BEYOND

### ARIX Technology

ARIX Technology places diamond particles in three dimensional patterns to deliver optimum performance.



Advanced multi-layered diamond segments with precise distribution of diamond particles throughout the segment

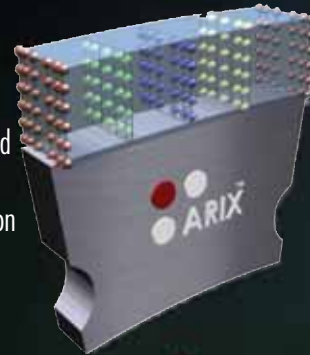

## ARIX PROFESSIONAL CURED CONCRETE DIAMOND BLADE - NORMAL APPLICATION CHART

Faster Speed  
Softer Aggregate ← → Harder Aggregate  
Lower Horsepower Higher Horsepower

AGGREGATE	C43AX-10	C53AX-10	C53AX-13	C63AX-13
SOFT	●	●		
MEDIUM SOFT	●	●	●	
MEDIUM HARD			●	●
HARD				●

Get faster cutting speed and longer life with ARIX™ precise diamond arrangement throughout each segment for unequaled performance.

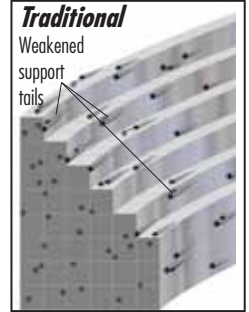
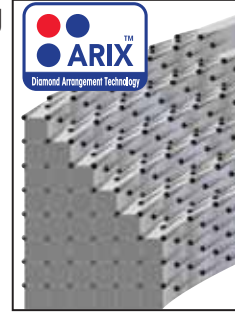

### C43-AX10

★★★★★ PRO IV

Diameter & Width	Part No.	List
14" x .125" x 1"-DP	D10065	\$639
14" x .187" x 1"-DP	D18316	925
14" x .250" x 1"-DP	D18318	1,185
18" x .125" x 1"-DP	D10067	784
18" x .145" x 1"-DP	D18324	914
18" x .160" x 1"-DP	D18325	1,017
20" x .125" x 1"-DP	D18329	968
20" x .145" x 1"-DP	D10068	1,028
20" x .160" x 1"-DP	D18331	1,076
24" x .160" x 1"-DP	D18333	1,401
26" x .160" x 1"-DP	D18517	1,454
26" x .160" x 1"-DP with insert	D18526	1,613

*insert for undercut protection*

**WET ONLY**  
10 mm / .393 in. segment height

### C53-AX13

★★★★★ PRO V

Diameter & Width	Part No.	List
18" x .125" x 1"-DP	D18397	\$1,142
20" x .160" x 1"-DP	D18390	1,325
20" x .160" x 1"-DP with insert	D18711	1,401
26" x .160" x 1"-DP with insert	D18651	1,942
26" x .160" x 1"-DP	D18391	1,797
26" x .187" x 1"-DP with insert	D18393	2,050
30" x .160" x 1"-DP with insert	D18713	2,158
30" x .187" x 1"-DP with insert	D18714	2,374
32" x .160" x 1"-DP with insert	D18715	2,482
36" x .160" x 1"-DP with insert	D18717	2,699
36" x .187" x 1"-DP with insert	D18718	2,915

*insert for undercut protection*

**WET ONLY**  
13 mm / .512 in. segment height

### C53-AX10

★★★★★ PRO V

Diameter & Width	Part No.	List
14" x .125" x 1"-DP	D18275	\$687
14" x .250" x 1"-DP	D18281	1,238
16" x .125" x 1"-DP	D18283	805
16" x .145" x 1"-DP	D18284	1,011
16" x .160" x 1"-DP	D18520	1,022
18" x .125" x 1"-DP	D18519	914
18" x .145" x 1"-DP	D18287	1022
18" x .160" x 1"-DP	D18288	1,130
18" x .187" x 1"-DP	D18290	1,293
20" x .125" x 1"-DP	D18292	1,022
20" x .145" x 1"-DP	D18293	1,076
20" x .160" x 1"-DP	D18294	1,185
20" x .187" x 1"-DP	D18386	1,401
24" x .145" x 1"-DP	D18295	1,401
24" x .160" x 1"-DP	D18296	1,454
24" x .187" x 1"-DP	D18298	1,617
26" x .160" x 1"-DP	D18300	1,563
26" x .160" x 1"-DP with insert	D18401	1,710
26" x .187" x 1"-DP	D18302	1,725
28" x .187" x 1"-DP	D18418	2,467
28" x .187" x 1"-DP with insert	D18724	2,617
30" x .160" x 1"-DP	D18303	1,833
30" x .160" x 1"-DP with insert	D18640	2,039
30" x .187" x 1"-DP	D18305	2,050
36" x .160" x 1"-DP	D18309	2,374
36" x .187" x 1"-DP	D18311	2,590
42" x .187" x 1"-DP	D18710	3,672
48" x .187" x 1"-DP	D18725	4,213

*insert for undercut protection*

**WET ONLY**  
10 mm / .393 in. segment height

### C63-AX13

★★★★★ PRO VI

Diameter & Width	Part No.	List
14" x .125" x 1"-DP	D14830	\$1,076
14" x .145" x 1"-DP	D14843	1,185
14" x .160" x 1"-DP	D18500	1,293
18" x .125" x 1"-DP	D14854	1,293
18" x .145" x 1"-DP	D18511	1,401
18" x .160" x 1"-DP	D14860	1,563
20" x .125" x 1"-DP	D14868	1,454
20" x .145" x 1"-DP	D18512	1,563
20" x .160" x 1"-DP	D18513	1,617
20" x .187" x 1"-DP	D18701	1,887
24" x .160" x 1"-DP	D14888	2,050
24" x .160" x 1"-DP with insert	D14893	2,242
24" x .187" x 1"-DP	D14892	2,211
26" x .160" x 1"-DP	D14900	2,158
26" x .160" x 1"-DP with insert	D14901	2,244
26" x .187" x 1"-DP	D14902	2,320
30" x .160" x 1"-DP	D18226	2,428
30" x .160" x 1"-DP with insert	D18688	2,531
30" x .187" x 1"-DP	D18231	2,536
32" x .160" x 1"-DP	D18232	2,915
36" x .160" x 1"-DP	D18235	3,023
36" x .160" x 1"-DP with insert	D18694	3,131
42" x .187" x 1"-DP	D18035	4,223

*insert for undercut protection*

**WET ONLY**  
13 mm / .512 in. segment height



WET ONLY  
13 mm / .512 in.  
segment height

## C42N-13 Traditional

★★★★ PRO IV High Performance

Fast Cut/Longest Life

Diameter & Width	Part No.	List
14" x .125" x 1"-DP	D13001	\$579
14" x .145" x 1"-DP	D13002	644
14" x .160" x 1"-DP	D13003	703
16" x .125" x 1"-DP	D13004	644
16" x .145" x 1"-DP	D13005	671
16" x .160" x 1"-DP	D13039	812
18" x .125" x 1"-DP	D13006	752
18" x .145" x 1"-DP	D13007	795
18" x .160" x 1"-DP	D13008	860
18" x .187" x 1"-DP	D13038	1,136
20" x .125" x 1"-DP	D13009	805
20" x .145" x 1"-DP	D13015	860
20" x .160" x 1"-DP	D13016	968
20" x .187" x 1"-DP	D13030	1,271
24" x .145" x 1"-DP	D13017	1,185
24" x .160" x 1"-DP	D13018	1,238

Diameter & Width	Part No.	List
24" x .160" x 1"-DP with insert	D13043	1,320
24" x .187" x 1"-DP	D13019	1,401
26" x .145" x 1"-DP	D13020	1,238
26" x .160" x 1"-DP	D13021	1,293
26" x .160" x 1"-DP with insert	D13029	1,401
26" x .187" x 1"-DP	D13022	1,422
30" x .160" x 1"-DP	D13023	1,509
30" x .160" x 1"-DP with insert	D13042	1,622
30" x .187" x 1"-DP	D13024	1,725
32" x .160" x 1"-DP	D13025	1,779
32" x .187" x 1"-DP	D13026	1,942
36" x .160" x 1"-DP*	D13027	2,103
36" x .187" x 1"-DP*	D13028	2,158
42" x .187" x 1"-DP*	D13036	3,071
48" x .187" x 1"-DP*	D13031	3,456

insert for undercut protection \* wide notch blades



WET ONLY  
13 mm / .512 in.  
segment height

## C72N-13 Traditional

★★★★★ PRO VII

Diameter & Width	Part No.	List
14" x .125" x 1"-DP	D14973	\$720
14" x .145" x 1"-DP	D14974	822
14" x .160" x 1"-DP	D14975	1,041
16" x .125" x 1"-DP	D14976	845
16" x .145" x 1"-DP	D14977	1,031
16" x .160" x 1"-DP	D14978	1,105
18" x .125" x 1"-DP	D14979	1,006
18" x .145" x 1"-DP	D14980	1,071
18" x .160" x 1"-DP	D14964	1,244
18" x .187" x 1"-DP	D14967	1,492
20" x .125" x 1"-DP	D14982	1,071
20" x .145" x 1"-DP	D14983	1,128
20" x .160" x 1"-DP	D14960	1,334
20" x .187" x 1"-DP	D14968	1,677
24" x .160" x 1"-DP	D14963	1,617
24" x .187" x 1"-DP	D14969	1,936
26" x .160" x 1"-DP	D14966	1,725
26" x .187" x 1"-DP	D14965	1,925
30" x .160" x 1"-DP	D14959	2,055
30" x .160" x 1"-DP with insert	D14984	2,235
30" x .187" x 1"-DP	D14970	2,542
36" x .160" x 1"-DP	D14971	2,542
36" x .160" x 1"-DP with insert*	D14986	2,645
36" x .187" x 1"-DP*	D14972	3,050

\* Wide notch blades Insert for undercut protection



WET ONLY  
13 mm / .512 in.  
segment height

## C82N-13 Traditional

★★★★★ PRO VIII

Diameter & Width	Part No.	List
14" x .125" x 1"-DP	D15063	\$773
14" x .145" x 1"-DP	D15058	884
14" x .145" x 1"-DP with insert	D15062	934
16" x .125" x 1"-DP	D15067	925
16" x .145" x 1"-DP	D15068	1,050
16" x .160" x 1"-DP	D15066	1,188
18" x .160" x 1"-DP	D15061	1,337
20" x .145" x 1"-DP with insert	D15071	1,240
20" x .160" x 1"-DP	D15051	1,434
24" x .160" x 1"-DP	D15052	1,738
26" x .160" x 1"-DP	D15054	1,854
26" x .160" x 1"-DP with insert	D15065	1,944
26" x .187" x 1"-DP with insert	D15055	2,177
30" x .160" x 1"-DP	D15053	2,403
30" x .160" x 1"-DP with insert	D15069	2,525
30" x .187" x 1"-DP with insert	D15056	2,840
36" x .160" x 1"-DP with insert*	D15070	3,095
36" x .187" x 1"-DP with insert*	D15057	3,386

\* Wide notch blades Insert for undercut protection

## PROFESSIONAL CURED CONCRETE

### DIAMOND BLADE - NORMAL APPLICATION CHART

Faster Speed ← Harder Aggregate  
Softer Aggregate → Higher Horsepower  
Lower Horsepower

AGGREGATE	C42N-13	C72N-13	C82N-13
SOFT	●		
MEDIUM SOFT	●	●	
MEDIUM HARD		●	●
HARD			●

## PROFESSIONAL CURED CONCRETE DIAMOND BLADE APPLICATION CHART - HARD ROCK

AGGREGATE	Faster Speed Very Hard		Critically Hard
	C-63N13	C-83AX13	C-83N13
VERY HARD	●	●	●
CRITICALLY HARD		●	●



### Diamond Blades for Hard Rock

Diameter & Width	C-63N13 Traditional PRO VI ★★★★★		C-83AX13 ARIX G3 PRO VIII ★★★★★★		C-83N13 Traditional PRO VIII ★★★★★★		D List
	Part No.	List	Part No.	List	Part No.	List	
14" x .125" x 1"-DP	D18021	\$1,076	D18902	\$1,095	D14113	\$1,095	
14" x .160" x 1"-DP			D18706	1,276	D14108	1,276	
18" x .125" x 1"-DP	D15423	1,293			D14114	1,325	
20" x .160" x 1"-DP	D14873	1,617	D18903	1,942	D14106	1,942	
26" x .160" x 1"-DP	D14861	2,060	D18702	2,173	D14110	2,173	
30" x .160" x 1"-DP			D18703	2,788	D14111	2,788	
36" x .160" x 1"-DP			D18705	3,395	D14112	3,395	

## PROFESSIONAL ELECTRIC FLAT SAW DIAMOND BLADE APPLICATION CHART

Horsepower	Faster Speed Harder Aggregate				Softer Aggregate
	C-42AX10	C-51AX13	C-42N13	C-43AX10	C-53AX10
10	●				
15	●	●			
20	●	●	●	●	
30		●	●	●	
40		●	●	●	●
50					●

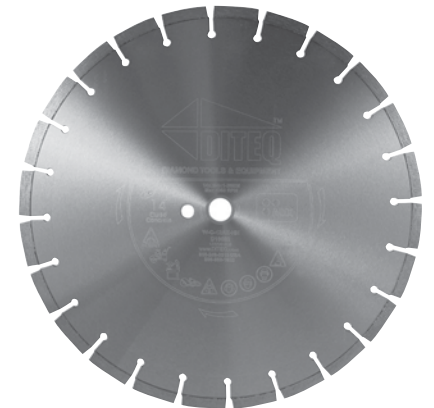

### Diamond Blades Electric Flat Saws

Diameter & Width	C-42AX10 ARIX PRO IV ★★★★		C-51AX13 ARIX G3 PRO V ★★★★★		C-42N13 Traditional PRO IV ★★★★★		C-43AX10 ARIX PRO IV ★★★★		C-53AX10 ARIX PRO V ★★★★★		D List
	Part No.	List	Part No.	List	Part No.	List	Part No.	List	Part	List	
14" x .125" x 1"-DP	D10073	\$481	D10111	\$536	D13001	\$579	D10065	\$639	D18275	\$687	
16" x .125" x 1"-DP			D18425	690							
18" x .125" x 1"-DP	D11063	649	D18420	749	D13006	752	D10067	784	D18519	914	
18" x .145" x 1"-DP			D18429	820	D13007	795	D18324	914	D18287	1,022	
20" x .125" x 1"-DP	D10075	644	D18730	925	D13009	805	D18329	968	D18292	1,022	
20" x .145" x 1"-DP	D10086	752			D13015	860	D10068	1,028	D18293	1,076	
20" x .160" x 1"-DP					D13016	968	D18331	1,076	D18294	1,185	
24" x .125" x 1"-DP	D10080	914	D18426	1,250			D18740	1,200			
24" x .145" x 1"-DP	D10102	1,076			D13017	1,185	D18332	1,293	D18295	1,401	
26" x .145" x 1"-DP					D13020	1,238					
26" x .160" x 1"-DP					D13021	1,293	D18517	1,454	D18300	1,563	
30" x .160" x 1"-DP					D13023	1,509	D18340	1,746	D18303	1,833	

# Professional High Horsepower Flat Saw Diamond Blades

Asphalt Overlay/  
Asphalt

## Asphalt Overlay Diamond Blades



WET ONLY  
13 mm / .512 in.  
segment height

### PROFESSIONAL ASPHALT OVERLAY DIAMOND BLADES

Faster Speed ← → Slower Speed

AGGREGATE	C-63AX13	C-82N13	C-73AX13
SOFT			●
MEDIUM		●	
HARD	●	●	

	C-63AX13 with Insert PRO VI  *****		C-82N13 with Insert PRO VIII *****		C-73AX13 with Wedge PRO VII  G3 ***** D	
Diameter & Width/Protection	Part No.	List	Part No.	List	Part No.	List
26" x .160" x 1"-DP	D14901	\$2,244	D15065	\$1,944	D18453	\$2,295
26" x .187" x 1"-DP	D18686	2,428	D15055	2,177	D18452	2,495
30" x .160" x 1"-DP	D18688	2,531	D15069	2,525		
30" x .187" x 1"-DP	D18690	2,644	D15056	2,840		
36" x .160" x 1"-DP	D18694	3,131	D15070*	3,095		
36" x .187" x 1"-DP	D18674	3,270	D15057*	3,386	D26325	2,176

\*wide notch

### PROFESSIONAL ASPHALT DIAMOND BLADES

Faster Speed Shorter Life ← → Slower Speed Longer Life

AGGREGATE	A46N	A46	A48	A56N	A58
SOFT			●	●	●
MEDIUM	●	●	●	●	
HARD	●	●			

## Asphalt Diamond Blades

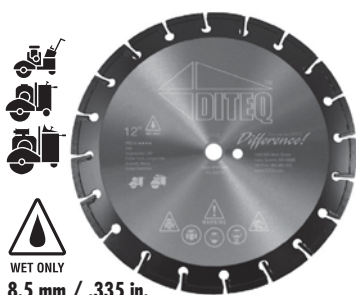

WET ONLY  
8.5 mm / .335 in.  
segment height

### A46N A46 A48 and A56N A58 Asphalt

	★★★★ PRO IV		★★★★★ PRO V					D
Diameter & Width	A46N13 PRO IV	List	A46 PRO IV	A48 PRO IV	A56N13 PRO V	List	A58 PRO V	List
14" x .125" x 1"-DP	D26301	\$613	D26133	D28312	D27001	\$730	D28396	\$784
14" x .145" x 1"-DP	D26302	658	D26135	D28316	D27002	784	D28400	892
14" x .160" x 1"-DP	D26303	814		D28318	D27003	968		
14" x .187" x 1"-DP	D26304	863	D26137	D28320	D27004	1,028		
14" x .250" x 1"-DP	D26305	1,067	D29336		D27005	1,271		
16" x .125" x 1"-DP	D26306	750	D26141	D28328	D27006	892	D28412	968
16" x .145" x 1"-DP	D26307	842	D28331	D28332	D27007	947	D28800	1,022
18" x .125" x 1"-DP	D26308	795	D26145	D28336	D27008	947	D28420	1,055
18" x .145" x 1"-DP	D26309	840	D26146	D28340	D27009	1,000	D28140	1,108
18" x .160" x 1"-DP	D26310	1,067	D26148	D28342	D27010	1,271	D28426	1,293
18" x .187" x 1"-DP	D26311	1,112	D26149	D28344	D27011	1,325		
18" x .250" x 1"-DP	D26312	1,292			D27012	1,537		
20" x .125" x 1"-DP	D26313	1,022	D26151	D28348	D27013	1,216	D28432	1,401
20" x .145" x 1"-DP	D26314	1,040	D28351	D28352	D27014	1,271	D28436	1,454
20" x .160" x 1"-DP	D26315	1,112	D26154	D28354	D27015	1,325	D28438	1,509
20" x .187" x 1"-DP	D26316	1,163			D27016	1,441		
24" x .160" x 1"-DP	D26317	1,295	D26161	D28368	D27017	1,541	D28452	1,617
24" x .187" x 1"-DP	D26318	1,514		D28370	D27018	1,725		
24" x .250" x 1"-DP	D26319	2,134			D27019	2,540		
26" x .160" x 1"-DP	D26320	1,449	D26165	D28376	D27020	1,725		
26" x .187" x 1"-DP	D26321	1,726	D26166	D28378	D27021	1,887		
30" x .160" x 1"-DP	D26322	1,817	D26550		D27022	2,163		
30" x .187" x 1"-DP	D26323	1,994	D29312		D27023	2,374		
36" x .160" x 1"-DP	D26324	2,085			D27024	2,518		
36" x .187" x 1"-DP	D26325	2,176		D28908	D27025	2,590		
42" x .187" x 1"-DP			D29342			3,780		

# Joint Widening / Joint Cleaning Diamond Blades / Wire Brushes

JOINT WIDENING BLADES					
AGGREGATE	C33	A38	A46N13	A46	A56N13
SOFT		●			●
MEDIUM	●			●	
HARD			●		

Blade Spacers			P
Diameter & Width	Part No.	List	
8" x .03" thick x 1"-DP	110092	\$12.36	
8" x .048" thick x 1"-DP	110107	10.00	
8" x .07" thick x 1"-DP	110093	12.36	
8" x .12" thick x 1"-DP	110094	13.39	
8" x .18" thick x 1"-DP	110095	16.48	
8" x .25" thick x 1"-DP	110096	19.57	

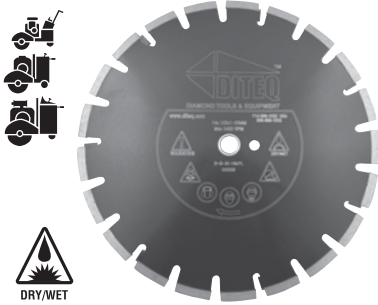

10 mm / .393 in.  
segment height

Diameter & Width	Super Premium			PRO IV		PRO V		D
	C33	A38	List	A46N13	List	A46	A56N13	
14" X .187" X 1"-DP	D12087	D24066	\$536	D26304	\$863	D26137	D27004	\$1,028
14" X .250" X 1"-DP	D12062	D24063	579	D26305	1,067	D29336	D27005	1,271
14" X .375" X 1"-DP	D12063	D24064	812			D28325		1,942
14" X .500" X 1"-DP	D12085	D24065	1,136					
18" X .250" X 1"-DP				D26312	1,292		D27012	1,537



Wire Brush			E
Diameter & Width	Part No.	List	
12" x 3/8" x 1"-DP	100218	\$87	

*Brushes are priced individually and sold 2 per box in whole box quantities only. Use only on low horsepower flat saws (5 to 20 hp). Require a 5/8" minimum blade clamping thickness.*



Bevel Blades			D
★★★ Super Premium			
Diameter & Width	Part No.	List	
12" x .375" x 1"-DP 45°	D22808	\$968	

# Green Concrete Diamond Blades / G-TEQ Early Entry Saws

## Green Concrete Diamond Blades

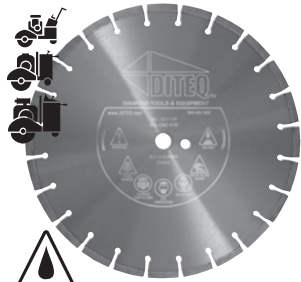

WET ONLY  
8.5 mm / .335 in.  
segment height

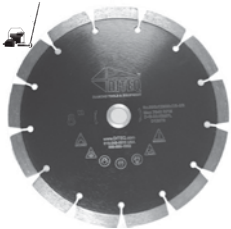

DRY/WET  
12 mm / .472 in.  
segment height

### PROFESSIONAL GREEN CONCRETE DIAMOND BLADES

AGGREGATE	A46	A48	A56N	A58	A59
SOFT					●
MEDIUM	●	●	●	●	
HARD	●	●	●		

### A46 A48 and A56N A58 A59

★★★★ PROIV Diameter & Width	★★★★★ PROV			List	A58	A59	List	D
	A46	A48	A56N13					
14" X .125" X 1"-DP	D26133	D28312	D27001	\$730	D28396	D28748	\$784	
14" x .145" x 1"-DP	D26135	D28316	D27002	784	D28400	D28750	892	
14" x .160" x 1"-DP		D28318	D27003	968				
14" X .187" X 1"-DP	D26137	D28320	D27004	1,028				
16" X .125" X 1"-DP	D26141	D28328	D27006	892	D28412	D28756	968	
16" X .145" X 1"-DP	D28331	D28332	D27007	947	D28800	D28800	1,022	
18" X .125" X 1"-DP	D26145	D28336	D27008	947	D28420	D28760	1,055	
18" X .145" X 1"-DP	D26146	D28340	D27009	1,000	D28140	D28620	1,108	
18" x .160" x 1"-DP	D26148	D28342	D27010	1,271	D28426		1,293	
18" x .187" x 1"-DP	D26149	D28344	D27011	1,325				
20" x .125" x 1"-DP	D26151	D28348	D27013	1,216	D28432		1,401	
20" X .145" X 1"-DP	D28351	D28352	D27014	1,271	D28436		1,454	
20" x .160" x 1"-DP	D26154	D28354	D27015	1,325	D28438		1,509	
20" X .187" X 1"-DP			D27016	1,441				

### G33 Segmented Green Concrete Blade

★★★ Super Premium	Part No.	List	D
8" x .095" x 5/8"-7/8"	D12079	\$163	
10" x .095" x 5/8"	D12088	205	



### G-TEQ Early Entry Saws - Push/Self-Propelled Models

Model No.	G-TEQ 450	G-TEQ 200E	G-TEQ 600
PUSH/SELF-PROPELLED	Push	Push	Self-Propelled
HORSEPOWER	4.5HP	2HP ELECTRIC	6 HP
ENGINE/MOTOR	Subaru EX13	120 V, 1 PHASE, 17 FLA	Subaru EX17
PART No.	F50001	F50002	F50007
LIST \$	\$3,085	\$3,239	\$7,133

Accessories	Part No.	List	P
Air Filter 4.5HP & 6 Subaru	100321	\$30.00	
Flat Trac™ blade roller kit	100301	173.00	
Wrench	100306	2.16	
Z-Arbor Outer Clamping Disc	100308	90.00	
Dust Chute	100311	45.00	
Handle Grips	100304	3.24	
Outer Clamping Disc Bolt	100309	1.08	



### G-TEQ Green Concrete Connection Blades

★★★ Super Premium	Hard Material		Soft Material		D
	GC-31	GC-32	GC-34	GC-36	
Diameter & Width	Purple	Green	Red	Yellow	List
6.5" x .095" x 8.5mm	D22301	D22302	D22303	D22304	\$146

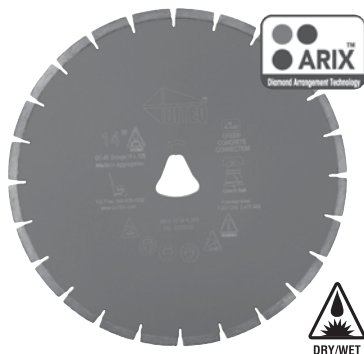

**EARLY ENTRY BLADE APPLICATION CHART FOR GREEN CONCRETE**

**CONNECTION AND LIBERTY BELL ARBOR BLADES**

Color Code	Purple	Green	Orange	Red	Yellow
Extremely hard aggregates, medium sharp sand	●				
Hard aggregates, sharp abrasive sand		●	●		
Medium aggregates, medium sharp sand		●	●	●	
Medium to hard aggregates, all types sand			●	●	
Medium soft aggregates, medium abrasive sand					●

**ARIX Liberty Bell Arbor Green Concrete Blades**

★★★★ PRO IV

Diameter & Width	Soff-Cut® Model	Material Hardness				D List
		GC-41AX Purple	GC-42AX Green	GC-45AX Orange	GC-46AX Yellow	
10" x .095" x 10mm	2000/2500	D22631	D22632	D22633	D22634	\$314
10" x .250" x 10mm	2000/2500	D22638	D22639	D22617	D22618	644
12" x .125" x 10mm	4000/4200/5000	D22601	D22612	D22607	D22635	466
12" x .250" x 10mm	4000/4200/5000	D22602	D22613	D22608	D22640	790
13.5" x .125" x 10mm	4000/4200	D22627	D22628	D22629	D22636	552
13.5" x .250" x 10mm	4000/4200	D22641	D22642	D22619	D22620	882
14" x .125" x 10mm	5000	D22604	D22630	D22610	D22637	589
14" x .250" x 10mm	5000	D22605	D22616	D22611	D22643	903

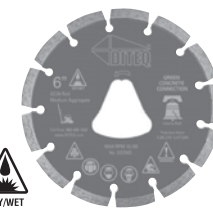
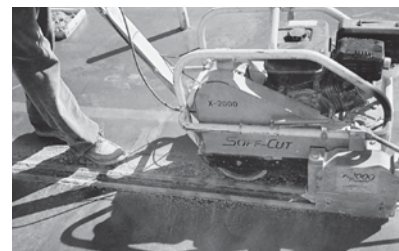

**Skid Plates for Soff-Cut Saws**



Description	Skid Plate Part No.	Soff-Cut® Model	P List
6"-8" x .125"	100608	150	\$40
9"-10" x .125"	100609	2000 / 2500	45
12"-13.5" x .125"	100610	4000 Prowler, 4200	50
12"-14" x .100"	100611	5000	55
9"-10" x .250"	100612	2000 Prowler / 2500	45
12"-13.5" x .25"	100613	4000 Prowler, 4200	50
12"-14" x .25"	100614	5000	55

**Liberty Bell Arbor Green Concrete Blades**

★★★ Super Premium

Diameter/Width	Material Hardness				D List
	GC-31 Purple	GC-32 Green	GC-34 Red	GC-36 Yellow	
6" x .095" x 10mm	D22501	D22502	D22503	D22504	\$146
8" x .095" x 10mm	D22506	D22507	D22508	D22509	238

**Skid Plate Refurbishment Kits**



Description	Boot'Em™ Part No.	CastAway™ Part No.	Soff Cut® Model	P List
5"-5.5" x .095"	100220	100236	390	\$17.51
6"-8" x .095"	100221	100237	150/750 Prowler, 450	17.51
6"-8" x .225"	100226	100242	150/750 Prowler, 450	19.57
9"-10" x .100"	100222	100238	2000 Prowler, 2500	21.00
9"-10" x .250"	100227	100243	2000 Prowler, 2500	23.00
12"-13.5" x .125"	100223	100239	4000 Prowler, 4200	23.00
12"-14" x .125"	100224	100240	5000	24.00
12"-13.5" x .250"	100230	100246	4000 Prowler, 4200	25.00
12"-14" x .250"	100233	100249	5000	24.00



**Deco Bevel Blades for Soff-Cut® Saws**

★★★ Super Premium

Diameter/Width	Bell Arbor Part No.	Z Arbor Part No.	D List
5" x 3/8" x 1/8" V	D22801	D22811	\$330
5" x 5/8" x 1/8" V	D22802	D22812	368
5" x 5/8" x 1/4" V	D22803	D22813	401
5" x 3/4" x 3/8" V	D22804		487
5" x 1" x 1/2" V	D22805		497
5" x 1/4" x 1/8" R	D22806	D22809	422
5" x 1/2" x 1/8" R	D22807	D22810	449

# Professional Ring Saw / Hand Saw / Diamond Blades / Diamond Chain

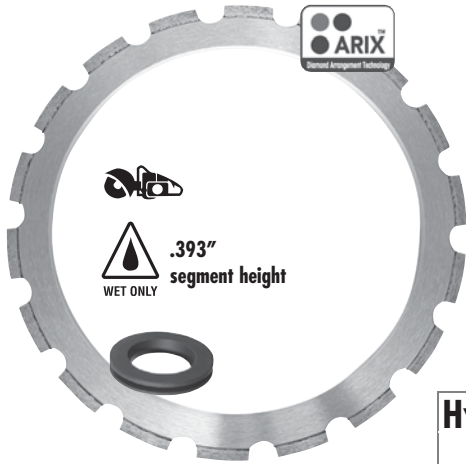

RING SAW DIAMOND BLADES		
AGGREGATE	C50AX	C51AX
SOFT		●
MEDIUM	●	●
HARD	●	

C50-AX and C51-AX Ring Saw Blades			
★★★★★ PRO V			
			D
Diameter & Width	C50-AX	C51-AX	List
14" x .160" x 10mm	D10107	D10077	\$427
14" x .220" x 10mm	D10108		536
			P
Accessories	Part No.		List
Drive Wheel	D10052		\$22
<i>Drive Wheel included with each blade</i>			

HYDRAULIC HAND SAW DIAMOND BLADES					
AGGREGATE	C42AX	C50AXW	C50AX	C51AXW	C51AX
SOFT	●				
MEDIUM	●		●	●	●
HARD		●	●	●	●

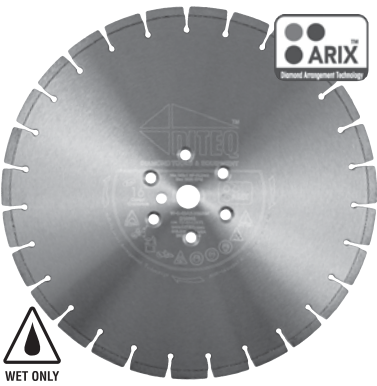

C42-AX / C50-AX / C51AX Hydraulic Hand Saw Blades									
★★★★ PRO IV									
									D
	C42-AX10	C50-AXW	C51-AXW	C50AX	C51AX				
	10mm	13mm	13mm	13mm	13mm				
	PRO IV	PRO V	PRO V	PRO V	PRO V				
Diameter & Width	Part No.	List	Part No.	Part No.	List	Part No.	Part No.	List	
14" x .125" x 1"	D10073	\$481	D10122	D10116	\$509	D10119	D10111	\$536	
16" x .125" x 1"	D10081	536	D10123	D10117	557	D10120	D10112	589	
16" x .165" x 1"	D10093	644							
20" x .125" x 1"	D10075	644	D10124	D10118	671	D10121	D10113	709	
24" x .125" x 1"	D10080	914		D10114	1,006				

DIAMOND CHAIN APPLICATION CHART				
AGGREGATE	C41 Gas	C42	C43	C44
SOFT	●		●	●
MEDIUM	●	●	●	●
HARD	●	●		



Diamond Chain					
Saw Type	C41 Gas Part No.	C42 Part No.	C43 Part No.	Bar Length	A List
Hydro No.853		140412	140336	11"	\$1,185
Hydro No.CC2020		140417	140341	12"	1,325
Hydro No.814		140410	140333	13"	1,076
Hydro No.853		140411	140335	15"	1,401
Hydro No.CC2020		140418	140342	16"	1,563
Hydro No.853		140413	140337	19"	1,649
Hydro No.CC2020		140419	140343	20"	1,833
Hydro No.853		140414	140338	24"	1,995
Hydro No.CC2020		140420	140344	24"	2,082
Gas No.613		140409	140332	12"	1,238
Gas No.633/K950		140415	140339	14"	1,346
Gas No.633		140416	140340	16"	1,487
Gas No.613	140426			12"	1,076
Gas No.633/K950	140427			14"	1,185
Gas No.633	140428			16"	1,293

Other sizes and specifications available.



Bulk Diamond Chain				
Saw Type	C41 Gas Part No.	C42 Part No.	C43 Part No.	C44 Part No.
Bulk - Sold by the Link	140425	140393	140346	140353
List A	\$19.57	\$23.00	\$23.00	\$23.00
Accessories	Part No.			List F
Assy. Tooling Complete	140570			\$682



Guide Bars for Diamond Chainsaws		
Description	Part No.	P List
Guide Bar, 11" No.853	140551	\$182
Guide Bar, 15", No.853	140552	237
Guide Bar, 19", No.853	140553	373
Guide Bar, 24", No.853	140554	736
Guide Bar, 13", Stanley LCC30, No.814	140556	212
Guide Bar, 12" No.614GC/680GC	140561	190
Guide Bar, 14", No.614GC/680GC/633 & K950	140562	212
Guide Bar, 16", No.633GC/680GC	140563	268

Other guide bars, nose and drive sprocket kits are available. Call for part numbers and pricing.

# Professional Wall Saw / Curb Saw / Diamond Blades / Wire

PROFESSIONAL WALL SAW DIAMOND BLADES	C41	C41AXW	C41AX
AGGREGATE			
SOFT	●		●
MEDIUM	●	●	●
HARD		●	

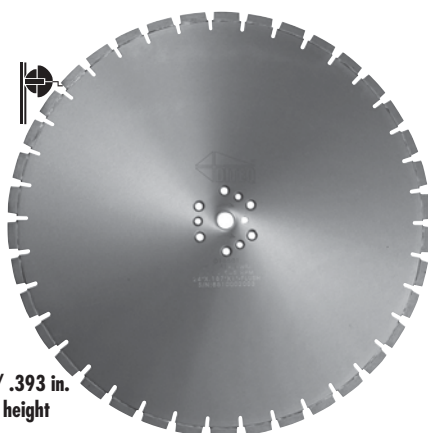

WET ONLY  
10 mm / .393 in.  
segment height

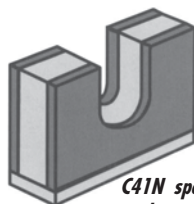

C41N spec features sand-wich segments for better tracking and maintaining side clearance

Additional arbor configurations including: GDM, Pentrunder, Braun, Multiquip, and Hilti available. Call for more information.

## C41N / C41AXW / C41AX Wall Saw Blades

★★★★ PRO IV

Generation II

Diameter & Width	C41N Longyear 1" Arbor		C41AXW Longyear 1" Arbor		C41AX Longyear 1" Arbor	
	Part No.	List	Part No.	List	Part No.	List
24" x .187"	D16015	\$1,000	D16551	\$1,282	D16501	\$1,509
24" x .220"			D16552	1,420	D16502	1,671
24" x .250"			D16553	1,834	D16503	2,158
26" x .187"	D16016	1,352	D16554	1,467	D16504	1,725
26" x .220"			D16555	1,632	D16505	1,920
26" x .250"			D16556	2,018	D16506	2,374
30" x .187"	D16017	1,433	D16557	1,650	D16507	1,942
30" x .220"			D16558	1,743	D16508	2,050
30" x .250"			D16559	2,156	D16509	2,536
32" x .187"			D16560	2,018	D16510	2,374
32" x .220"			D16561	2,158	D16511	2,570
32" x .250"			D16562	2,662	D16512	3,131
36" x .187"	D16018	2,158	D16563	2,247	D16513	2,644
36" x .220"			D16564	2,294	D16514	2,699
36" x .250"			D16565	2,846	D16515	3,348
42" x .187"			D16566	2,846	D16516	3,348
42" x .220"			D16567	2,983	D16517	3,509
42" x .250"			D16568	3,673	D16518	4,321
48" x .187"					D16519	3,672

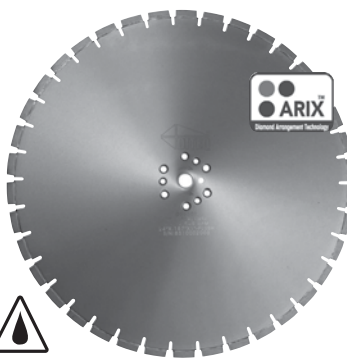

WET ONLY  
10 mm / .393 in.  
segment height

## C42-AX10 Curb Cut Blades

★★★★ PRO IV

Diameter & Width	Part No.	List
20" x .250" x 1"	D16656	\$1,942
22" x .220" x 1"	D16645	1,617
24" x .250" x 1"	D16603	2,289
26" x .187" x 1"	D16604	1,829

## Diamond Wire

Diameter & Width	Part No.	List
<b>Construction Spring Wire</b>		
C42-R	D91015	\$351
C42-Vacuum Coated* Edge	D91016	351
Vacuum Coated	D91014	319
C41AX Wire	D91017	379
C42AX Wire	D91018	379
<b>Stone-Urethane</b>		
C31AX	D91019	351
C30AX	D91020	351

\*leading edge vacuum brazed Prices per meter length.

Diamond Wire Crimps	Part No.	List
3/16" ID x 3/8" OD x 3/4" L	151157	\$1.08
3/16" ID x 3/8" OD x 1-1/8" L	151304	4.33



# Wet Diamond Core Bits

WET DIAMOND CORE BITS							
AGGREGATE	C22	C32	C43	C51	C52	C53	C62AX
SOFT	●	●	●		●	●	
MEDIUM		●		●	●		●
HARD		●		●			●

20" - 30" Diameter = 23" barrel  
31" - 48" Diameter = 35" barrel



1-1/4"-7 thread

C62AX WET Core Bit		
★★★★★PRO VI		
Diameter	Part No.	List <i>D</i>
2"	D34101	\$228
2 1/4"	D34102	249
2 1/2"	D34103	260
2 3/4"	D34104	281
3"	D34105	298
3 1/2"	D34106	351
4"	D34107	406
4 1/4"	D34108	459
4 1/2"	D34109	514
5"	D34110	536
5 1/2"	D34111	595
6"	D34112	644
6 1/4"	D34113	730
6 1/2"	D34114	752
7"	D34115	805
8"	D34116	860
9"	D34117	1,022
10"	D34118	1,076
12"	D34119	1,401
14"	D34120	1,725

Other sizes available upon request

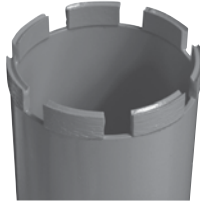

WET ONLY

C51 / C52 Segmented / Double Pointed					
★★★★★ PRO V					
Dia.	C51		C52		<i>D</i> List
	Solid Back Part No.	List	Solid Back Part No.	Open Back Part No.	
1"			D32321		\$141
1-1/8"			D32322		146
1-1/4"			D32323		151
1-3/8"			D32324		168
1-1/2"			D32325		178
1-5/8"			D32326		184
1-3/4"			D32327		190
1-7/8"			D32328		195
2"	D36101	\$175	D32201	D33401	200
2-1/4"	D36102	191	D32202		228
2 1/2"	D36103	201	D32203	D33402	243
2-3/4"	D36104	221			
3"	D36105	232	D32205	D32274	276
3-1/4"	D36106	258	D32285		319
3 1/2"	D36107	283	D32207	D33403	336
4"	D36108	304	D32208	D32260	368
4-1/4"	D36109	361	D32209		406
4 1/2"	D36110	386	D32210	D33405	427
5"	D36112	407	D32212	D33406	459
5 1/2"	D36113	438	D32213		487
6"	D36115	464	D32215	D32261	589
6-1/4"	D36116	510	D32216		644
6 1/2"	D36117	561	D32217		697
7"	D36118	613	D32218	D32277	752
7-1/2"			D32291		784
8"	D36119	664	D32219	D33408	805
8-1/2"			D32292		892
9"	D36120	798	D32220	D33409	947
10"	D36121	870	D32221	D33410	1,000
11"			D32230		1,216
12"	D36122	953	D32222		1,293
13"	D36132	1,391			
14"	D36123	1,128	D32223		1,454
16"	D36124	1,586	D32232		1,725
18"	D36125	1,777	D32233		2,190
20"	D36126	2,060	D32234		2,374
24"			D32235		3,293
26"			D32231		4,699
30"			D32238		5,348
33"			D33417		7,102

1" - 1-3/4" are crown

1" - 6" are laser welded  
6-1/4"> are brazed  
16" and above standard with spoke back

Solid or welded backs and special barrel lengths are available upon request

1" - 1-1/2" are 5/8"-11  
Remainder are 1-1/4"-7 thread





## C32 Segmented/Pointed Brazed

★★★ PRO III

D

Diameter	Part No.	List
3/8"	D32041	\$103
1/2"	D32042	103
5/8"	D32043	108
3/4"	D32044	113
7/8"	D32045	113
1"	D32046	119
1 1/8"	D32047	130
1 1/4"	D32048	135
1 3/8"	D32049	146
1 1/2"	D32050	151
1 5/8"	D32051	163
1 3/4"	D32052	168
1 7/8"	D32053	178

3/8" - 1-3/4" are C32 crown  
1" - 1-1/2" are 5/8"-11 thread  
1-5/8" and up are 1-1/4"-7 thread



**Laser Welded**

.315" seg. height

\*5/8"-11 thread for hand held drills

\*\*1-1/4"-7 thread for rig mounted drills

9" drilling depth

## C34 ARIX Short Dry Bit

★★★ Super Premium

For Reinforced Concrete

Diameter	Standard*		Pro**	
	Part No.	List	Part No.	List
1-1/4"	D31543	\$135		
1-1/2"	D31521	146	D31532	\$146
1-3/4"	D31522	163		
2"	D31523	190	D31534	190
2-1/4"	D31524	200	D31535	200
2-1/2"	D31525	221	D31536	221
3"	D31526	233	D31537	233
3-1/2"	D31527	271	D31538	271
4"	D31528	324	D31539	324
4-1/2"	D31529	394	D31540	394
5"	D31530	433	D31541	433
6"	D31531	471	D31542	471

## C43/C53 Segmented/Prestressed Concrete & Asphalt

C43

C53

Diameter	C43 PRO IV		C53 PRO V	
	Part No.	List	Part No.	List
2"	D32124	\$200	D33143	\$238
2-1/4"	D32125	206		
2-1/2"	D32126	211		
3"	D32128	271	D33144	330
3-1/2"	D32130	319		
4"	D32131	373	D33164	422
4-1/4"	D32132	416	D33173	474
4-1/2"	D32133	427		
5"	D32135	487		
5-1/2"	D32136	536		
6"	D32138	644		
6-1/4"	D32139	692		
6-1/2"	D32140	752		
7"	D32141	805		
8"	D32142	860		
10"	D32144	1,185		



8 mm / .315 in. segment height

1-1/4"-7 thread

**Brazed**



5/8"-11 thread

1" and 1-1/4" .275" segment hgt

1-1/4" and above .315" segment hgt

9" drilling depth

**Laser Welded**

## C25 Short Dry Bit

★★ Premium For Block Only

Diameter	Part No.	List
1"	D31501	\$66
1-1/4"	D31502	70
1-1/2"	D31503	76
1-3/4"	D31504	92
2"	D31505	98
2-1/4"	D31506	103
2-1/2"	D31507	125
3"	D31508	141
3-1/2"	D31509	200
4"	D31510	238
4-1/2"	D31511	265
5"	D31512	298
6"	D31513	336

## C22 Turbo Core Bit

★★ Premium

D

Diameter	Part No.	List
1-1/2"	D32082*	\$92
2"	D32086	135
2-1/2"	D32088	163
3"	D32090	190
3-1/2"	D32092	233
4"	D32093	254
4-1/2"	D32095	286
5"	D32097	308
6"	D32100	351
7"	D32103	519
8"	D32104	584
9"	D32105	682
10"	D32106	752



\*5/8"-11 thread  
All others are 1-1/4"-7 thread  
.413" segment height



Use your Hammer Drill to drill clean holes with these adapters and DITEQ's C34 ARIX Dry Bit!

## Hammer Drill Adapters for Diamond Core Bits

Description	Part No.	P List
SDS Max to SDS Plus Chuck	151617	\$103
SDS Max to 5/8-11M Rotary adapter	151623	73
SDS Plus to 5/8-11 Rotary Adapter	151670	73

# Retipping Machines and Diamond Segments

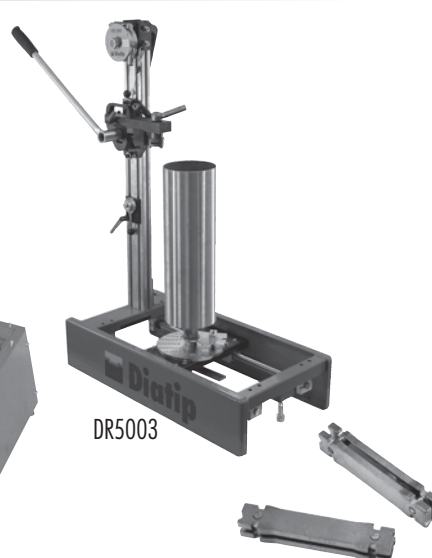
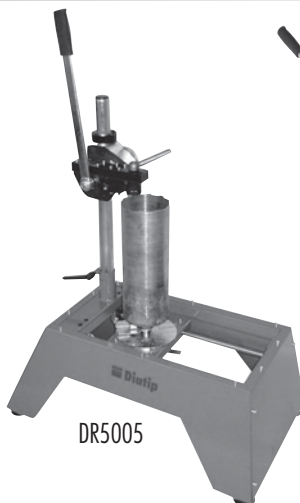
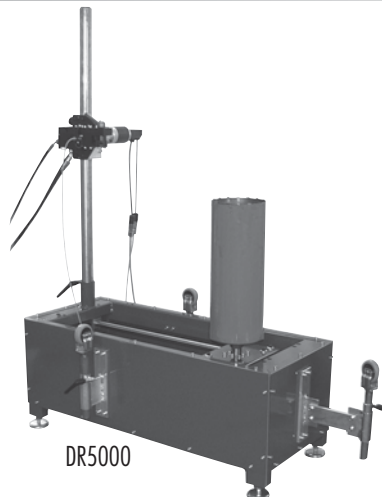

## Diatip™ Diamond Core Bit Retipping Machines

	CD 600 Economy	CD 7-28 Manual	CD 7-28 Automatic	CD 7-28 Grande
Power			110V/60 Hz	110V/60 Hz
Amps/Volts				
Minimum Bit Diameter	2-1/8"	2-1/8"	2-1/8"	2-1/8"
Maximum Bit Diameter	28"	28"	28"	60"
Core Bit Maximum Length	22"	22"	22"	22"
Maximum Steel Thickness	.125"	.125"	.125"	.125"
<b>Part No.</b>	DR5003	DR5002	DR5001	DR5000
List Price <b>E</b>			Call for Pricing	

*Diatip Machines are special order items*

## Retipping Accessories

	Part No.	List	
Superstrong Flux Magnet - each magnet has four different side clearances: 0.02"/0.03"/0.04" and 0.05" (0.5mm/1.0mm & 1.25mm) (Standard for segments 2" - 16")	151167	\$91	<b>E</b>
US magnet, each magnet has four different side clearances: 0.06"/0.07"/0.08"/and 0.09" (1.5mm/1.78/2.03mm/2.3mm (for larger segments)	151627	91	<b>E</b>
Flux (35 oz. jar)	151141	238	<b>P</b>
Matrice 1-3/8"-2-1/2" dia 16 mm seg	151325	*	
Knife 16 mm seg.	151326	*	
Knife 24 mm seg.	151168	*	
CD7-28 Ext. 18"	151181	*	
CD7-28 Ext. 12"	151193	*	
CD600 Ext. 36"	151138	*	

\* Call for pricing

## C32 Pointed Segments ★★ ★ Super Premium

Diameter	Part No.	Thickness	Segment Length	Segment Height	List	D
4 - 6.5"	D35014	.165"	.945"	.315"	\$16.48	
7 - 9"	D35015	.187"	.945"	.315"	16.48	
10 - 14"	D35019	.187"	.945"	.315"	18.54	
10 - 16"	D35016	.210"	.945"	.315"	22.00	
10 - 16"	D35017	.250"	.945"	.315"	27.00	
18 - 36"	D35018	.250"	.945"	.315"	27.00	

## C62AX Segments ★★ ★ ★ ★ PRO VI

Diameter	Part No.	Thickness	Segment Length	Segment Height	List	D
2" - 2.5"	D35051	.145"	.945"	.393"	\$22	
2.75" - 3.5"	D35052	.145"	.945"	.393"	22	
4 - 6.5"	D35053	.160"	.945"	.393"	24	
7 - 9"	D35054	.165"	.945"	.393"	25	
10 - 14"	D35055	.187"	.945"	.393"	27	
10 - 16"	D35056	.210"	.945"	.393"	33	
14 - 36"	D35057	.250"	.945"	.393"	38	

## C52 Double Pointed Segments ★★ ★ ★ ★ PRO V

Diameter	Part No.	Thickness	Segment Length	Segment Height	List	D
2" - 2.5"	D35032	.145"	.945"	.420"	\$16.48	
2.75" - 3.5"	D35033	.145"	.945"	.420"	16.48	
2.75" - 3.5"	D35042	.160"	.945"	.420"	19.57	
2.75" - 3.5"	D35077	.187"	.945"	.420"	22.00	
2" - 3.5"	D35079	.250"	.945"	.420"	33.00	
4 - 6.5"	D35034	.165"	.945"	.420"	19.57	
5" - 7"	D35078	.187"	.945"	.420"	22.00	
7 - 9"	D35035	.165"	.945"	.420"	19.57	
10 - 14"	D35036	.187"	.945"	.420"	22.00	
10 - 16"	D35037	.210"	.945"	.420"	27.00	
14 - 36"	D35038	.250"	.945"	.420"	33.00	

**DITEQ offers retipping services - Call for information**

### Core Drill Power Requirements:

**Generator: Watt = Volt X Amps.** Calculating your wattage needs is a little more complex than simply adding up the rated watts, because the motors require a surge of wattage to get started. If you do not include surge wattage in your calculations, you can underestimate your power output and possible damage your motor and generator.

**Generator: Minimum - 3,500 watts Recommended (TS-092, TS-132, TS-162 and TS-252) - 5,000 watts for 27 amp motors.** Use 30 amp generator circuit and 10 gauge extension cord for best performance with 27 amp motors (TS-402, TS-403, TS-503 and TS-603).

# SHIBUYA Professional Core Drill Machines - Hand Drills and TS-092

## Hand Held Drills

	D-Handle Hand Held RH1531	Pistol-Grip Hand Held RH1532	RH1531 ABV Combo Drill RH1531
<b>MOTOR</b>			
AMPS/VOLTS	15/115	15/115	15/115
RPM (Under Load)	560/1400/2900	560/1400/2900	560/1400/2900
BIT CAPACITY	(Max. Handheld) 4"	(Max. Handheld) 4"	8" (Angle)
BIT CAPACITY			10" (Vertical)
COLUMN LENGTH			39.4"
WEIGHT w/o accessories	15 lb (6.8 kg)	15 lb (6.8 kg)	69 lb. w/pump
MODEL No.	RH1531	RH1532	RH1531ABV
<b>PART No.</b>	<b>DR2003</b>	<b>DR2023</b>	<b>DR2024</b>
<b>List E</b>	<b>\$1,833</b>	<b>\$2,158</b>	<b>\$3,245</b>

RH1531 220V models available

Hand Drill Accessories	Part No.	List P
Stand, Fixed base, column & carriage	150340	\$805
Stand, Angle base, column & carriage	150341	1,022
Dust/Slurry Ring (5")	151291	195
Dust/Slurry Ring (7")	151287	195
Adaptor kit/Squeeze clamp	150342	141
Adaptor kit/Fixed bolt on	150343*	60
Grease Tube	151082	45
Brass quick disconnect	150590	7.57

\*RH1531D-Handle model only

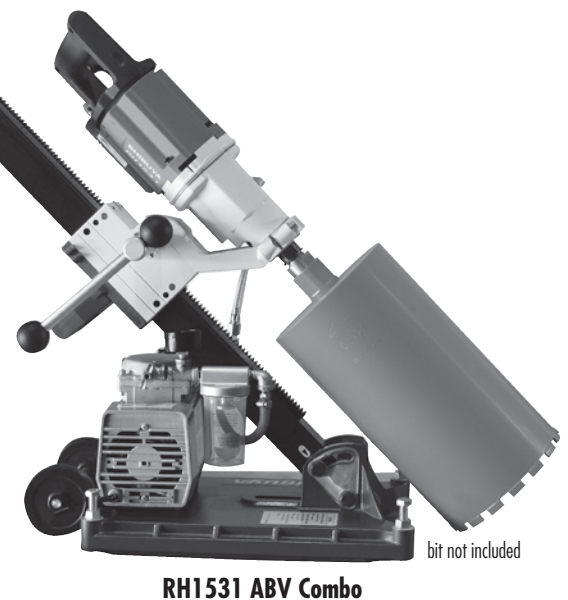

## TS-092

	w/ CASE	w/ CASE
BASE STYLE	ANGLE ANCHOR	ANGLE ANCHOR
<b>MOTOR</b>	<b>R1011</b>	<b>R1012</b>
AMPS	10	10
RPM (no Load)	970	1750
BIT CAPACITY (Max.)	6"	4"
COLUMN LENGTH	22" (560mm)	22" (560mm)
WEIGHT w/o accessories	20 lb	20 lb
MODEL No.	TS-092ABKIT	TS-092ABKIT
<b>PART No.</b>	<b>DR0017</b>	<b>DR0019</b>
<b>List E</b>	<b>\$1,725</b>	<b>\$1,725</b>

220V models available

TS-092 Accessories	Part No.	List P
Vacuum Pads - Extra Small	150159	\$211
Vacuum Pads - Small	150001	265
Vacuum Pump Assembly	150004	589

# SHIBUYA Core Drills - TS-132/TS-162



bit not included



Molded plastic storage cases keeps accessories organized

TS-132	TS-132 15 amps - 1 Speed				TS-132ABV 15 amps - 1 Speed
	Without Case		With Case		
	FIXED	ANGLE BASE	FIXED	ANGLE BASE	
BASE STYLE					Angle Base Combo
MOTOR			R1511		R1511
AMPS/VOLTS			15/115		15/115
RPM (No Load)			850		850
BIT CAPACITY (Max.)			9"		10" Vertical/8" Angle
COLUMN LENGTH	31.5" (800mm)	39.4" (1000mm)	23.5" short	23.5" short	39.4" (1000mm)
WEIGHT w/o access.	28.7 lb (13 kg)	33.8 lb (15.3 kg)	33.5lb (15.2kg)	33.5lb (15.2kg)	64 lb (14 kg) w/pump
MODEL No.	TS132	TS132AB	TS132KIT	TS132ABKIT	TS-132ABV
<b>PART No.</b>	<b>DR0001</b>	<b>DR0002</b>	<b>DR0011</b>	<b>DR0003</b>	<b>DR0037</b>
<b>List E</b>	<b>\$1,779</b>	<b>\$1,995</b>	<b>\$2,050</b>	<b>\$2,158</b>	<b>\$2,295</b>

220V models available

TS-132 Accessories	Part No.	List E
Small Vacuum Pad	150001	\$265
Standard Gast Vacuum Pump	150004	589
Premium Shibuya Vacuum Pump	150005	1,785

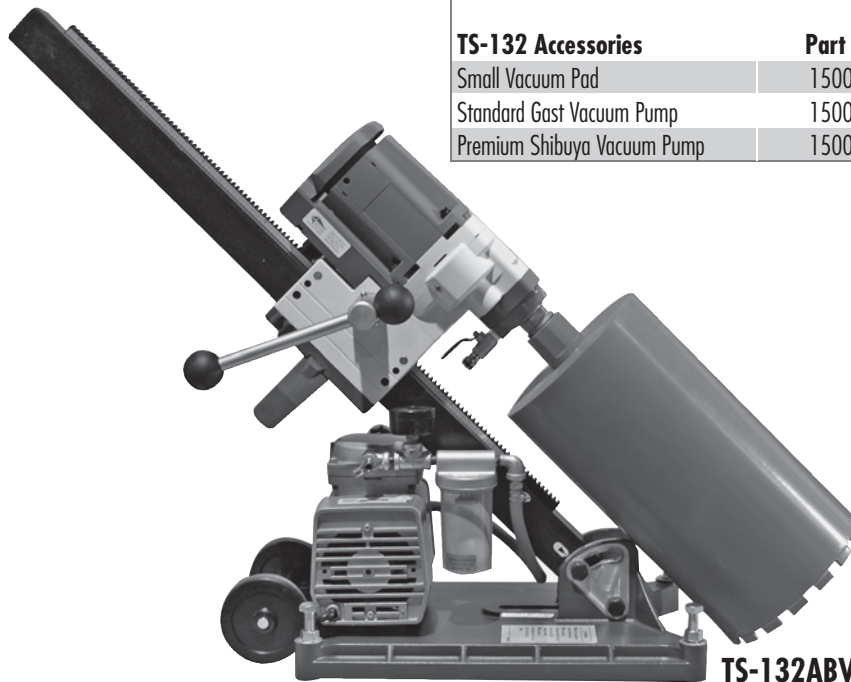

TS-132ABV  
bit not included



bit not included

TS-162	TS-162 15 amps - 2 Speed				TS-162ABV 15 amps - 2 Speed
	Without Case		With Case		
	FIXED	ANGLE BASE	FIXED	ANGLE BASE	
BASE STYLE					ANGLE BASE COMBO
MOTOR			R1521		R1521
AMPS/VOLTS			15/115		15/115
RPM (No Load)			700/1000		700/1000
BIT CAPACITY (MAX)			9"		10" Vertical/8" Angle
COLUMN LENGTH	31.5" (800mm)	39.4" (1000mm)	23.5" short	23.5" short	39.4" (1000mm)
WEIGHT w/o access.	30.9 lb (14 kg)	36 lb (16.3 kg)	35.7 lb (16.2 kg)	35.7 lb (16.2kg)	66 lb.
MODEL No.	TS162	TS162AB	TS162KIT	TS162ABKIT	TS-162ABV
<b>PART No.</b>	<b>DR0004</b>	<b>DR0005</b>	<b>DR0012</b>	<b>DR0006</b>	<b>DR0036</b>
<b>List E</b>	<b>\$1,942</b>	<b>\$2,158</b>	<b>\$2,320</b>	<b>\$2,428</b>	<b>\$2,495</b>

220V models available

TS-162 Accessories	Part No.	List E
Small Vacuum Pad	150001	\$265
Standard Gast Vacuum Pump	150004	589
Premium Shibuya Vacuum Pump	150005	1,785

<b>TS-252</b>	<b>TS-252</b>			<b>TS-252ABV</b>
<b>BASE STYLE</b>	FIXED	FIXED	ANGLE BASE	ANGLE BASE COMBO
MOTOR	R1721			
AMPS/VOLTS	20/115			
RPM (No Load)	450/900			
BIT CAPACITY (Max.)	12"			12" Vertical/10" Angle
COLUMN LENGTH	31.5" (800mm)	39.4" (1000mm)	39.4" (1000mm)	39.4" (1000mm)
WEIGHT w/o accessories	40.1 lb (18.2 kg)	43 lb (19.2 kg)	42.3 lb (19.2 kg)	73 lb. w/pump
MODEL No.	TS252	TS252	TS252AB	TS-252ABV
<b>PART No.</b>	<b>DR0007</b>	<b>DR0008</b>	<b>DR0009</b>	<b>DR0034</b>
<b>List E</b>	<b>\$2,644</b>	<b>\$2,752</b>	<b>\$2,860</b>	<b>\$2,995</b>

*220V models available*

<b>TS-252 Accessories</b>	<b>Part No.</b>	<b>List</b>	
Large Vacuum Pad - TS252	150002	<b>\$401</b>	<b>E</b>
Standard Gast Vacuum Pump	150004	<b>589</b>	<b>E</b>
Premium Shibuya Vacuum	150005	<b>1,785</b>	<b>E</b>
Optional Ceiling Jack	150160	<b>55</b>	<b>P</b>
Optional 51" 1 piece column	150609	<b>536</b>	<b>P</b>

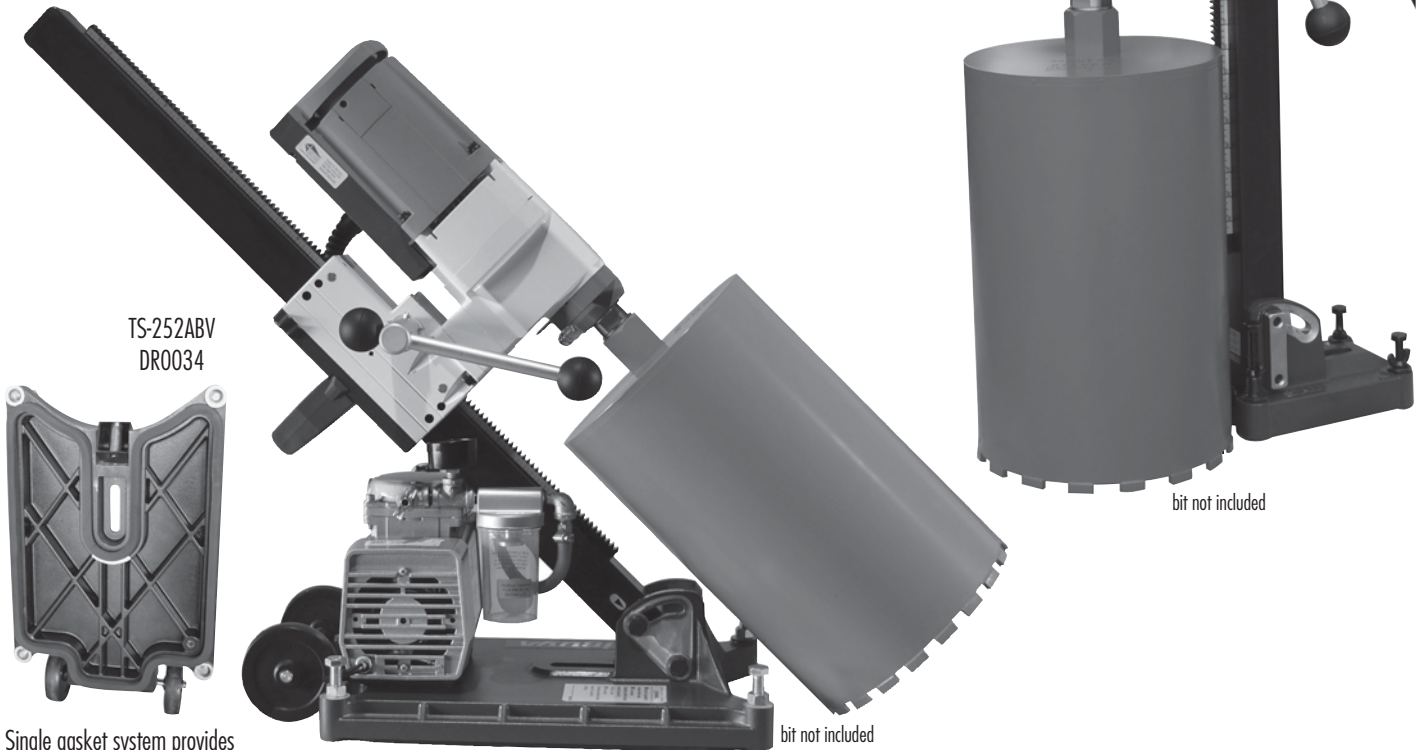

Single gasket system provides a stronger vacuum



## Auto Feed 9-Speed

	<b>Part No.</b>	<b>List</b>	
Auto-Feed - AF22 115V	150038	<b>\$3,564.00</b>	<b>E</b>
Auto-Feed - AF22 220V	150354	<b>3,672.00</b>	<b>E</b>
Remote Feed System - TS-503/603 115V	151290	<b>7,133.00</b>	<b>E</b>
Adapter Kit - TS-252	150320	<b>90.00</b>	<b>P</b>
Adapter Kit Left - TS-132/162	150321	<b>78.00</b>	<b>P</b>
Adapter Kit Right - TS-132/162	150322	<b>78.00</b>	<b>P</b>
Depth Stop Clamp	150477	<b>73.00</b>	<b>P</b>
Quick Pin Fed Handle	150142	<b>18.54</b>	<b>P</b>

# SHIBUYA Core Drills - TS-353



bit not included

**DR1047**  
Angle Base Combo

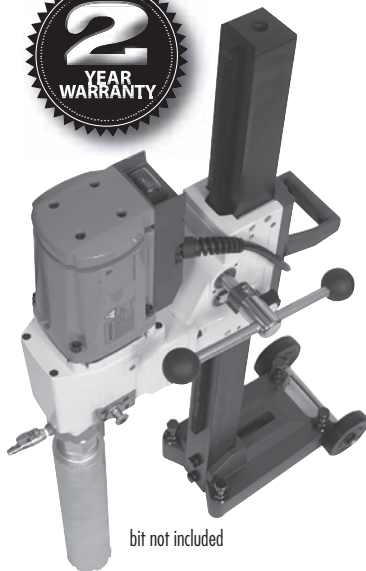

bit not included

<b>TS-353</b>	<b>TS-353</b> 23 amps - 3 Speed		<b>TS-353ABV</b> 23 amps - 3 Speed
BASE STYLE	FIXED	FIXED w/swivel/ext kit	ANGLE BASE COMBO
MOTOR	R2031		R2031
AMPS/VOLTS	23 / 115		23 / 115
RPM - Standard	380/1000/1700		380/1000/1700
BIT CAPACITY	14"-16" (with spacer)		14" Vertical, 12" Angled
COLUMN LENGTH	39.4" (1000mm)		39.4" (1000mm)
WEIGHT	68.8 lb.	68.8 lb	87 lb.
MODEL No.	TS353	TS353SW	TS-353ABV
PART No.	DR1017	DR1024	DR1047
<b>List E</b>	<b>\$3,509</b>	<b>\$3,888</b>	<b>\$3,695</b>

*Only available in 115V*

<b>TS-402</b>	<b>TS-403</b>			
	<b>27 amps - 2 Speed</b>	<b>27 amps - 3 speed</b>		
BASE STYLE	FIXED	FIXED	ANGLE	ANGLE
MOTOR	R2221	R2231		w/swivel/ext kit
AMPS/VOLTS	27 / 115	27 / 115		
RPM - Standard	300/700	300/800/1400		
RPM - Optional		400/1200/2000		
BIT CAPACITY	14"-16" (with spacer)	14"-16" (with spacer)		
COLUMN LENGTH	39.4" (1000mm)	39.4" (1000mm)		
WEIGHT	68.8 lb.	68.8 lb.	69.9 lb.	68.8 lb.
MODEL No.	TS-402	TS403	TS403AB	TS403SW
PART No.	DR1001	DR1003	DR1004	DR1011
<b>List E</b>	<b>\$3,564</b>	<b>\$3,726</b>	<b>\$4,429</b>	<b>\$4,105</b>

*220V models available*

<b>TS-353 / TS-402/403 Accessories</b>	<b>Part No.</b>	<b>List P</b>
Column Assy - TS353/TS-402/403 (59" one piece)	150766	<b>\$644</b>
Column Assy w/swivel/ext. kit - TS353/TS-402/403 (39"+19.5" two piece)	150770	<b>1,185</b>
Ceiling Jack - TS353/TS-402/403	150160	<b>55</b>
Angle Base - TS353/TS-402/403	150025	<b>1,055</b>
Extra Large Anchor Base	150998	<b>968</b>

# SHIBUYA Core Drills - TS-503 / TS-603



bit not included

<b>TS-603</b>	<b>HAWG</b>
	<b>27amps - 3 speed</b>
BASE STYLE — Large	FIXED ANCHOR
MOTOR	R2531
AMPS/VOLTS	27/115
RPM	150/300/600
Standard BIT CAPACITY	26"
COLUMN LENGTH	43" (1100mm)
COLUMN SIZE	2-7/8"
WEIGHT	138 lb
<b>PART No.</b>	<b>DR1010</b>
<b>List E</b>	<b>\$9,296</b>
<i>220V models available</i>	

<b>TS-503</b>	<b>TS-503</b>	<b>TS-503</b>
	<b>27-amps - 3 Speed</b>	<b>27-amps - 3 Speed</b>
BASE STYLE	FIXED	ANGLE
MOTOR	R2231	R2231
AMPS/VOLTS	27/115	27/115
RPM	300/800/1400	300/800/1400
BIT CAPACITY	18"	18"
COLUMN LENGTH	43" (1100mm)	43" (1100mm)
COLUMN SIZE	2-7/8"	2-7/8"
WEIGHT w/o accessories	113 lb	113 lb
<b>PART No.</b>	<b>DR1009</b>	<b>DR1041</b>
<b>List E</b>	<b>\$7,025</b>	<b>\$7,565</b>
<i>220V models available</i>		

<b>TS-503 / TS-603 Accessories</b>	<b>Part No.</b>	<b>P List</b>
TS-503 / TS-603 Angle Anchor Base only	151632	\$1,509
TS-503 / TS-603 Angle Anchor Base with Column	151530	2,915
Extension kit, column - TS-503 / TS-603 (22.75")	150393	519
Brace Kit, column - TS-503/TS-603 (can use w/column ext.)	150394	519
Swivel Kit, column - TS-503/TS-603 (15")	150395	416



bit not included

**TS-603**  
**HAWG**



bit not included

<b>Hydraulic Core Drill Rigs</b>				
Motor	OMS80	OMS160	OMS250	OMS400
Displacement	80cc	160cc	250cc	400cc
RPM	500 at 10 gpm	250 at 10 gpm	160 at 10 gpm	100 at 10 gpm
Max. Bit Cap.	8"	16"	24"	32"
Column Size	2-3/8"	2-7/8"	2-7/8"	2-7/8"
Column Length	39.4"	43"	43"	43"
Model No.	TS-420H	TS-540H	TS-660H	TS-680H
<b>Part No.</b>	<b>DR1026</b>	<b>DR1027</b>	<b>DR1028</b>	<b>DR1029</b>
<b>List E</b>	<b>\$6,700</b>	<b>\$9,728</b>	<b>\$10,053</b>	<b>\$10,053</b>

## Hydraulic Motor Assemblies

MOTOR	Danfoss OMS80	Danfoss OMS160	Danfoss OMS250	Danfoss OMS400
Displacement	80cc	160cc	250cc	400cc
RPM'S	500 at 10 GPM	250 at 10 GPM	160 at 10 GPM	100 at 10 GPM
Bit Diameter	8"	16"	24"	32"
<b>PART No.</b>	<b>151271</b>	<b>151272</b>	<b>151273</b>	<b>151274</b>
<b>List E</b>	<b>\$5,078</b>	<b>\$5,078</b>	<b>\$5,078</b>	<b>\$5,078</b>

*Assemblies include motor spindle, flow control, adapter plate and disconnect. Hydraulic motors only are also available.*

<b>Hydraulic Motor Accessories</b>	<b>Part No.</b>	<b>P List</b>
Adapter —1-1/4-7" male — A - rod female	151276	\$168
Quick Release	150039	427
Flow Control Valve Manifold	151269	1,725
Pillow Block Assembly - A-rod Spindle	151270	2,374
Hydraulic Hose 30' x 5/8" set of 2	151277	920

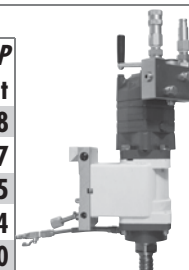

# SHIBUYA Drill Motors / Hydraulic Core Drills / Generators



<b>Motors</b>				<b>E</b>
Description	Part No.	List		
R1721 115V 20A 450/900 RPM	150027	\$1,617		
R2031 115V 23A 380/1000/1700 RPM	151053	1,942		
R2221 115V 27A 300/700 RPM	150028	2,103		
R2231 115V 27A 300/800/1400 RPM	150029	2,266		
R2231 220V 13A 300/800/1400 RPM	150330	2,266		
R2531 220V 13A 150/300/600 RPM (HAWG)	150473	4,321		

<b>Motor Adapter Kits</b>				<b>P</b>
Description	Part No.	List		
Adapter Plate Kit for most competitors 2-7/8" carriages for Shibuya motors	150311	\$211		
Adapter Kit - 2-7/8" rig x R17 motor (20A)	150869	184		

<b>Wall Mount</b>				<b>E</b>
Description	Part No.	List		
Wall Mount - 4"-8"	150323	\$752		

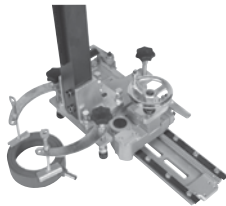

<b>Stitch Drill Cradle</b>				<b>E</b>
Description	Part No.	List		
Stitch Drill Cradle - TS402/403	150722	\$5,208		
Track - 600mm	150405	1,028		
Track - 1200mm	150406	1,785		



- Standard Wall Saw Kit:
- 27 amp electric motor RS2521 2 speed
  - 1-1.2 m Track
  - 1-0.6m Track
  - Travel Motor
  - Auto Travel Control
  - 30" Blade Guard

<b>SHIBUYA Wall Saw</b>	
	<b>SS300R Plunge</b>
DIMENSIONS SAW HEAD & CHASSIS	743 (H) X 350 (W) X 463 (H)
MOTOR	RS2521 2-Speed
POWER SUPPLY	115 Volts/1 PH
SPINDLE RPM (no load)	300/700
RATED INPUT	2.5 KW
TRACK	1-1.2m Track / 1-0.6m Track
BLADE CAPACITY	30"
BLADE ARBOR DIAMETER	27mm
WEIGHT - SAW HEAD & CHASSIS	80 lb
<b>PART No.</b>	<b>WS0002</b>
<b>List E</b>	<b>\$19,900</b>



<b>Slurry Rings</b>				<b>P</b>
Description	Part No.	List		
8" Slurry Ring	150012	\$146		
10" Slurry Ring	150013	168		
12" Slurry Ring	150014	211		
14" Slurry Ring	150015	319		



<b>Slurry Ring Fixture*</b>				<b>P</b>
Description	Part No.	List		
Fixture - TS252 (4"-10")**	150020	\$146		
Fixture - TS402/403 (14"-18")**	150023	319		

*\*Use with slurry rings above \*\* Bit size*



<b>BitBuddie</b>				<b>E</b>
Description	Part No.	List		
1-3/8" dia. bits w/hose	160220	\$53		
1" to 4" dia. bits (round) w/hose	160979	53		
2-8" dia. bits (round)	161625	61		



<b>WCR Water Slurry Rings</b>				<b>P</b>
Description	5" Part No.	7" Part No.	List	
WCR Slurry Ring	151291	151287	\$195	
Cover Plate Slurry Ring	151292	151288	48	
Gasket Slurry Ring	151293	151289	6.49	



<b>Water Tanks</b>				<b>E</b>
Description	Part No.	List		
Aluminum Super Prem. w/pump	150006	\$427		
Standard Steel w/pump	151055	129		



<b>Subaru Generators Multi-Duty Industrial Gensets</b>				<b>E</b>
Description	Part No.	List		
Genset, RGX6500	150459	\$2,777		
Genset, RGX6500E*	150460	3,095		
RGX 7500	150461	3,511		
RGX 75000E*	150462	3,807		
Genset, RGV12100*	150463	5,787		

*\*w/o Battery Full line of Subaru generators is available. Call for details.*



<b>Subaru Water Pumps</b>				<b>E</b>
Description	Part No.	List		
Pump, 1" Centrifugal PKV101	110011	\$497		
Pump, 2" Centrifugal PKX201	110012	637		
Pump, 2" Trash PKX201T	110017	1,383		
Pump, 2" High Pressure PKX201H	110021	1,082		

Vacuum Pumps	Part No.	List	P
Standard Gast Vacuum Pump	150004	\$589	E
Premium Shibuya Vacuum Pump w/tank	150005	1,785	E
Jar, vacuum pump	150539	26	P
Ball, vacuum pump	150540	13.39	P



Vacuum Pads	Part No.	List	P
Step Vac Pad-RH1531/1532, TS-092/132/162	150874	\$211	E
Extra Small Vac Pad - R1531 TS092/132/162	150159	211	
Small Std Vac Pad - R1531 TS132/162	150001	265	
Large Standard Vac Pad - TS252	150002	401	
Extra Large Std. Vac Pad TS402/403	150003	595	
Small Twin / Pipe Pad	150036	805	
Large Twin / Pipe Pad	150037	914	
Pro Vacuum Pad w/wheels	151286	1,187	
Pro Vacuum Pad w/wheels & Gast Pump	151285	1,758	
Pro Vacuum Pad w/wheels & Shibuya Pump	151421	2,708	

Gaskets	Part No.	List	P
Gasket - X-small Pads / Small Twin Pad	150570	\$42	
Gasket - Small Pads	150215	47	
Gasket - Large Pads	150216	71	
Gasket - X-Large Pads	150409	47	
Gasket - Large Twin Pads	150571	71	
Gasket - Combo Pad	151802	37.50	

Water Seals/Swivels/Valves	Part No.	List	P
Water Seal - R10/R15/R17 motors (2 Req'd)	150070	\$13.39	
Water Seal - R20/R22/R25 motors (2 Req'd)	150083	13.39	
Water Swivel - R10 motors	150484	66	
Water Swivel - R15/R17 motors	150074	76	
Water Swivel - R20/R22/R25 motors	150085	82	
Water Valve w/nipple	150318	30	
Water Hose Valve w/nipple assy	150456	81	
Garden Hose Quick Disconnect - Brass	150590	7.57	

Switches and Circuit Protectors	Part No.	List	P
Switch/Circuit Protector - R10 motors 115V	150486	\$90	
Trigger Switch - RH 1531 115V hand drill	150442	98	
Circuit Protector - RH 1531 115V hand drill	150447	36	
Rocker Switch - RH15 hand-held/rig mode change 115V	150450	28	
Switch/Circuit Protector - R15 Motors & RH15 rig mode	150120	82	
Switch/Circuit Protector - R17 motor 115V TS-252	150121	82	
Switch - R22/R25 motors 115V TS-402/403	150122	64	
Switch/Circuit Protector - R22/R25 motors 220V	150478	82	
Circuit Protector - R22/R25 motors 115V TS402/403	150124	72	
Switch/circuit protector - R20 115V TS-353	151100	90	

Carbon Brushes	Part No.	List	P
Carbon Brush - RH15/R15/R17/R20 motors 115V (2 Req'd)	151668	\$8.65	
Carbon Brush - R22/R25 motors 120V (2 Req'd)	151669	8.65	
Carbon Brush - R15/17/22 motors 220V (2 Req'd)	150416	9.73	
Carbon Brush - R10 motors 115V (2 Req'd)	150485	9.73	

Carriages	Part No.	List	P
Standard 2-7/8" Roller Carriage	151435	\$860	
Pro 2-7/8" Roller Carriage Assy w/quick release motor mount - TS503 (18" bit)	150381	2,482	
Pro 2-7/8" Roller Carriage Assy w/quick release motor mount - TS603 (26" bit)	150382	2,699	

Quick Release Motor Mount	Part No.	List	P
Quick Release Motor Mount - TS402/403/503/603	150039	\$427	
Quick Release Motor Mount - R1721 / TS252	150310	427	

Threaded Adapters	Part No.	List	P
Hilti Adapter, DD200 x 1-1/4" -7	151464	\$427	
Hilti Adapter, (spline x 1-1/4"-7M)	150589	427	
Hilti Adapter, DD100, DD130 (Slots x 1-1/4"-7M)	151066	76	
Hilti Adapter, DD100, DD130 (Slots x 5/8")	151065	60	
Adapter 1-1/4"-7F to 5/8"-11 M	150024	48	
Adapter 5/8"-11 F to 1-1/4"-7 M	150764	48	
3/8" shank, 5/8"-11M	150217	30	
1/2" shank, 5/8"-11M	150983	27	
1/2 Gas Thread x 5/8" 11 short	150421	30	
1/2 Gas Thread x 5/8" 11 long	150329	82	
1/2" Gas Thread x 1-1/4"-7 M	150052	103	

Extensions	Part No.	List	P
Ext., 5/8"-11 x 12" L	150509	\$90	
Ext., 5/8"-11 x 6" L	150547	78	
Ext., 1-1/4"-7 x 6" L	150161	94	
Ext., 1-1/4"-7 x 12" L	150043	103	
Ext., 1-1/4"-7 x 24" L	150890	167	
Ext., 1-1/4"-7 x 36" L	151664	263	

Spacers	Part No.	List	P
4" Spacer Kit- TS-402/403/503/603	150079	\$221	
1-1/4" Spacer Kit - TS402/403	150312	92	
1-1/4" Spacer Kit - TS252	150514	87	

Gear Clamps/Clutch	Part No.	List	P
Socket, Clutch - R motors	150051	81	
Gear Clamp - R17/R22/R25 motors	150054	81	
Gear Clamp - R15 motors	150055	81	
Gear Clamp - RH1531 hand drill	150506	24	

Tools/Miscellaneous	Part No.	List	P
Crows Foot - 36mm R17/R22/R25 motors	150049	190	
Crows Foot - 32mm R15 motors	150050	190	
4 Spoke Feed Handle -TS-252/353402/403/503/603	150758	211	
Ratchet - 19/21mm - TS402/403/503/603	150537	33	
Ratchet - 17/19mm - TS252	150877	38	
Wrench, Spindle, 36mm - R17/R22 motors	150513	15.45	
Wrench, Spindle, 32mm - R15/R15 motors	150535	15.45	

Diamond Bit Accessories	Part No.	List	P
Washer, Copper 1-1/4"-7 core bit	150653	8.65	
Washer, Plastic 1-1/4"-7 core bit	150654	3.24	

# SHIBUYA Core Drill Accessories / Parts and Hammer Drills / Bits



<b>TEQ-Hammer II PHD-40M</b>	
Rated Power	1100 Watts
Power Supply	110-120V
Hertz	50/60 Hz
Bit capacity (Max)	1-9/16" (concrete)
No-Load Speed (forward)	235-500 RPM
Variable Speed	6 Position
Full Load Impact Rate/Min	1350-2870 BPM
Impact Force	9.5j/7 ft lb
Tool Holder	<b>SDS-Max</b>
Net Weight	13 lbs.
Model No.	PHD-40M
<b>Part No.</b>	<b>DR2022</b>
<b>List E</b>	<b>\$557</b>

**DITEQ carries a wide variety of hammer bits and flat chisels. Contact customer service or our website for details**



<b>Carbide SDS Max Drill Bits</b>			
<b>Part No.</b>	<b>Size/Description</b>	<b>Usable Length</b>	<b>List E</b>
150905	1/2" x 13"	8"	<b>\$67</b>
150906	5/8" x 13"	8"	<b>81</b>
150907	7/8" x 13"	8"	<b>94</b>

*Numerous bits available in a variety of specs for SDS Plus and SDS Max Hammer Drills. Many bits are available in bulk packs or individual display packages. Call for info.*

## Rotary Dry Core Bit Adapters



**Use your hammer drill like a core drill with these rotary adapters!**

<b>Adapters</b>	<b>Part No.</b>	<b>List P</b>
<b>Description</b>		
SDS Max to SDS Plus Chuck	151617	<b>\$103</b>
SDS Max to 5/8-11M Rotary adapter	151623	<b>73</b>
SDS Plus to 5/8-11 Rotary Adapter	151670	<b>73</b>



<b>Pro Fastnut and Washer</b>	<b>Part No.</b>	<b>List P</b>
<b>Description</b>		
Pro Fastnut - 1/2" - 13	150327	<b>\$76</b>
Heavy Square Washer - 1/2"	150615	<b>9.73</b>



<b>Steel Smart Drop-in Anchors</b>			<b>List E</b>
<b>Size</b>	<b>Part No.</b>		<b>List Each</b>
1/2" - 13	151700		<b>\$1.08</b>
5/8" - 11	151701		<b>3.24</b>

*Other sizes and types of anchors, setting tools and bits are available. One free hand setting tool with each 100 piece or more order*

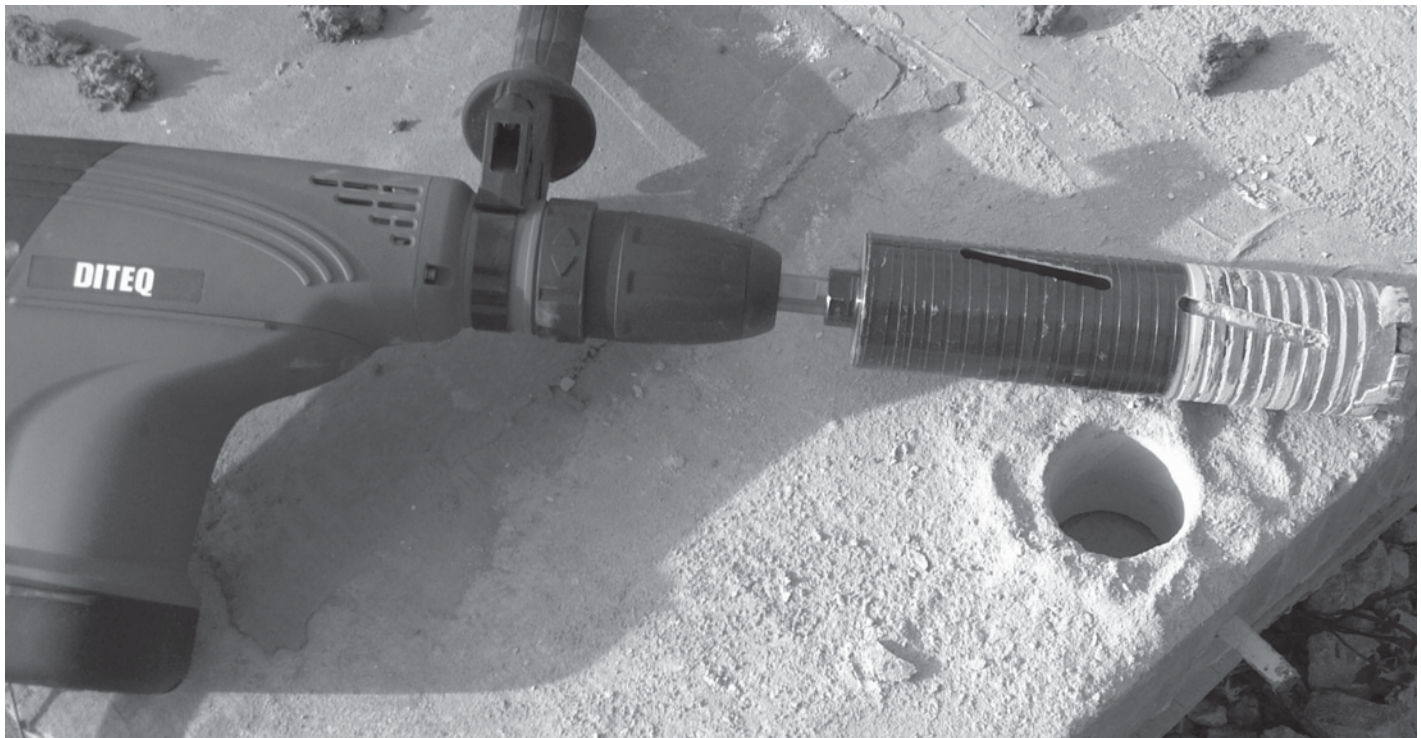

# High Speed & General Purpose Flat Saw Diamond Blades

Material	HIGH SPEED & GENERAL PURPOSE FLAT SAW SEGMENTED BLADES															
	C/A44 ARIX	C/A34GD Guardian	C/A24	D23 Utility/ Rescue	C-43 ARIX	C-33 ARIX	U23 XTRA	U13 U22	DXS XTRA	DXS XTRA	A36 ARIX	U/ A26	U/A16	G33	D25	
Hard Brick				●		●										
Brick		●	●	●	●	●	●	●	●	●						
Cured Concrete	●	●	●	●	●	●	●	●	●	●						
Concrete w/ Steel	●	●		●	●	●										
Stone		●		●		●										
Clay Tile		●	●	●												
Block/Pavers	●	●	●	●	●	●	●	●	●	●	●	●	●	●		
Green Concrete	●	●		●							●	●	●	●		
Asphalt	●	●	●	●							●	●	●			
Ductile Iron				●											●	
Steel				●												
Glass				●												
Fiberglass				●												
Plastic				●												

## PROFESSIONAL COMBO BLADES



**C-44AX Combo** *DITEQ's Do All Blades*  
**★★★★ PRO IV High Performance**  
**with Undercut Protection**

Diameter & Width	Part No.	List
12" x .125" x 1" 20mm DP	D10098	\$427
14" x .125" x 1" 20mm DP	D10082	471
16" x .125" x 1" DP	D10095	536
18" x .125" x 1 DP	D10084	589
20" x .125" x 1 DP	D10087	697

DRY/WET  
 .393" seg height  
 Laser Welded



**C/A-34GD Guardian Combo**  
**★★★ Super Premium**  
*Fast Cut/Longest Life*

Diameter & Width	Part No.	List
12" x .125" x 1/20mm DP	D11030	\$363
12" x .125" x 20mm DP	D11050	363
14" x .125" x 1/20mm DP	D11031	406
14" x .125" x 20mm DP	D11051	406
16" x .125" x 1/20mm DP	D11032	487
16" x .125" x 20mm DP	D11052	487
18" x .125" x 1/20mm DP	D11033	589
20" x .125" x 1/20mm DP	D11034	752

DRY/WET  
 .512" seg. height  
 3 Segment Design



**C/A 24 Combo**  
**★★ Premium** *Fast Cut/Long Life*

Diameter & Width	Part No.	List
12" x .125" x 1" 20mm	D10201	\$238
12" x .125" x 20mm	D11058	238
14" x .125" x 1"-20mm	D11042	249
14" x .125" x 20mm	D11059	249
16" x .125" x 1"-20mm	D10202	308
16" x .125" x 20mm	D11060	308

DRY/WET  
 .591" seg height  
 Laser Welded

## PROFESSIONAL BLADES

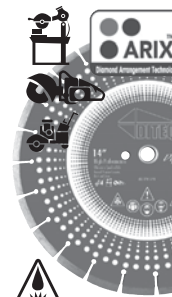

**C-43AX**  
**★★★★ PRO IV High Performance**  
*Fast Cut/Longest Life Cured Concrete*

Diameter & Width	Part No.	List
12" x .125" x 1" 20mm DP	D10058	\$406
14" x .125" x 1" 20mm DP	D10053	444
14" x .125" x 20mm DP	D10069	444
16" x .125" x 1" 20mm DP	D10054	519
16" x .125" x 20mm DP	D10070	519
18" x .125" x 1" DP	D10055	536
20" x .145" x 1" DP	D10056	644

DRY/WET  
 .393" seg. height  
 Laser Welded

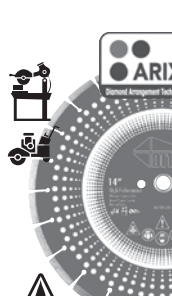

**C-33AX**  
**★★★ Super Premium**  
*Fastest Cut/Long Life - Cured Concrete*

Diameter & Width	Part No.	List
12" x .125" x 1" 20mm DP	D11021	\$286
12" x .125" x 20mm DP	D11026	286
14" x .125" x 1" 20mm DP	D11022	319
14" x .125" x 20mm DP	D11027	319
16" x .125" x 1" 20mm DP	D11023	389
18" x .125" x 1" DP	D11024	427
20" x .145" x 1" DP	D11025	536
24" x .160" x 1" DP	D11028	805

DRY/WET  
 .393" seg. height  
 Laser Welded

Shaft Adapter		P
Description	Part No.	List
20mm to 1 inch	161778	\$3.09

# High Speed & Small Diameter General Purpose Diamond Blades

## PREMIUM/ECONOMY BLADES



**U23 Xtra Segmented Blade**  
 ★ ★ Premium Gen. Purpose / Fast Cut / Longest Life  
 Cured Concrete / Brick / Block D

Diameter & Width	Part No.	List
14" x .125" x 1"-20mm +DP	D70069	\$211

**Laser Welded**  
 .512 in. segment height



**DX Xtra-S**  
 ★ Fast Cut / Long Life  
 Cured Concrete / Brick / Block D

Diameter & Width	Part No.	List
12" x .125" x 1"-20mm	D96231	\$135
14" x .125" x 1"-20mm	D96230	146
16" x .125" x 1"-20mm	D96232	211

**.591" seg. height**

## GREEN CONCRETE / ASPHALT BLADES



**U-22 General Purpose**  
 ★ ★ Premium Fast Cut / Good Life  
 Cured Concrete / Brick / Block D

Diameter & Width	Part No.	List
4" x .080" x 7/8"-5/8"	D70001	\$40
4" x .080" x 20mm-5/8"	D70002	40
4.5" x .080" x 7/8"-5/8"	D70003	60
5" x .080" x 7/8"-5/8"	D70004	68
6 x .080" x DM-7/8"-5/8"	D70005	74
7" x .080" x DM-7/8"-5/8"	D70006	81
8" x .085" x DM-7/8"-5/8"	D70007	92
9 x .095" x 7/8"-5/8"	D70008	106
10" x .095" x DM-7/8"-5/8"	D70009	113
12" x .125" x 20mm DP	D70012	\$125
12" x .125" x 1"-20mm DP	D70013	125
14" x .125" x 20mm DP	D70016	141
14" x .125" x 1"-20mm +DP	D70017	141
16" x .125" x 1"-20mm +DP	D70085	168

**Laser Welded**  
 .393 in. segment height



**A36AX**  
 ★ ★ ★ Super Premium  
 Fast Cut / Long Life  
 Asphalt / Green Concrete / Lightweight Block D

Diameter & Width	A36AX	List
12" x .125" x 1"-20mm DP	D24501	\$368
14" x .125" x 1"-20mm DP	D24502	389
16" x .125" x 1"-20mm DP	D24503	427
18" x .135" x 1" DP	D24504	536
20" x .135" x 1" DP	D24505	644
24" x .160" x 1" DP	D24511	968

**.393" seg. height**  
**Laser Welded**



**U13-Xtra General Purpose Segment**  
 ★ Fast Cut / Long Life -  
 Cured Concrete / Brick / Block D

Diameter & Width	Part No.	List
14" x .125" x 1"-20mm	D70080	184

**.512" seg. height**  
**Laser Welded**



**U-A26 Universal Segmented**  
 ★ ★ Premium  
 Block / Green Concrete / Asphalt D

Diameter & Width	Part No.	List
12" x .125" x 1"-20mm DP	D70072	\$200
14" x .125" x 1"-20mm DP	D70073	228
16" x .125" x 1"-20mm DP	D70086	281

**.393" seg. height**  
**Laser Welded**

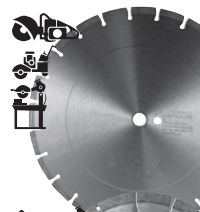

**DX-S Universal Segmented Blade**  
 ★ Economy, Fast Cut  
 Cured Concrete / Brick / Block

Diameter & Width	Part No.	List
4" x .080" x 7/8"-5/8"	D96205	\$22
4.5" x .080" x 7/8"-5/8"	D96206	25
5" x .080" x 7/8"-5/8"	D96220	30
6" x .080" x 7/8"-5/8"	D96221	42
7" x .080" x DM-7/8"-5/8"	D96207	47
8" x .085" x DM-7/8"-5/8"	D96222	60
9" x .095" x 7/8"-5/8"	D96223	66
10" x .095" x DM-7/8"-5/8"	D96208	83
12" x .125" x 1" - 20mm	D96214	98
14" x .125" x 1" - 20mm	D96215	103

**.393" seg. height**

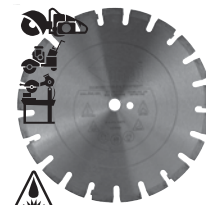

**U-A16 Segmented Blade**  
 ★ General Purpose, Fast Cut / Good Life  
 Green Concrete / Asphalt / Block D

Diameter & Width	Part No.	List
14" x .125" x 1"-20mm DP	D70088	\$151

**.472" seg. height**



**G33 Segmented**  
 ★ ★ ★ Super Premium  
 Green Concrete and Abrasive Materials D

Diameter & Width	Part No.	List
8" x .095" x 5/8"-7/8"	D12079	\$163
10" x .095" x 5/8"	D12088	205

**12 mm / .472 in. segment height**

SEE PAGE 8 FOR G-TEQ GREEN SAW AND BLADES

# High Speed & Special Purpose Diamond Blades

### HIGH SPEED & GENERAL PURPOSE FLAT SAW TURBO STYLE BLADES APPLICATION CHART

Material	C33		B22		U23ST	U13ST	DXT
	Firestar	Firehawk	Firehawk	Firehawk			
Hard Brick			●	●	●	●	●
Brick	●	●	●	●	●	●	●
Cured Concrete	●	●	●	●	●	●	●
Stone	●	●	●	●	●	●	●
Clay Tile	●	●	●	●	●	●	●
Block/Pavers	●	●	●	●	●	●	●



### C33 Firestar

★★★ Super Premium

Diameter & Width	Part No.	List
4.5" x .070" x 7/8"-5/8"	D57116	\$48
5" x .080" x 7/8"-5/8" Flush	D57107	55
7" x .095" x DM-7/8"-5/8"	D57101	108
8" x .095" x DM-7/8"-5/8"	D57102	125
10" x .110" x DM-7/8"-5/8"	D57106	190
12" x .110" x 1"-20mm DP	D57103	271
14" x .125" x 1"-20mm DP	D57104	351

DRY/WET  
.393 in. segment height



### B22 Firehawk III Multi-Purpose Turbo Blade

★★ Premium Fast Cut

Diameter & Width	Part No.	List
4" x .095" x 7/8 - 5/8" flush	D58013	\$38
4.5" x .095" x 7/8 - 5/8" flush	D58012	43
5" x .095" x 7/8 - 5/8" flush	D58011	48
6" x .095" x 7/8 - 5/8" flush	D58018	70
7" x .095" x 7/8 - 5/8" DM	D58014	92
10" x .110" x 7/8 - 5/8" DM	D58015	178
12" x .110" x 1" - 20mm DP	D58016	233
14" x .125" x 1" - 20mm DP	D58017	286

DRY/WET  
.472" segment height



### D23 Construction Utility/Rescue

★★ Premium  
Fast Cut/Multi-Purpose

Diameter & Width	Part No.	List
4.5" x .125" x 7/8"-5/8"	D11102	\$92
5" x .125" x 7/8"-5/8"	D11103	103
6" x .125" x 7/8"-5/8"	D11106	134
7" x .125" x DM-7/8"-5/8"	D11104	157
10" x .125" x DM-7/8"-5/8"	D11105	265
12" x .125" x 1-20mm	D10061	308
14" x .125" x 1-20mm	D10057	319
16" x .125" x 1-20mm	D10100	536

DRY/WET  
.200" seg. height



### U23ST Segmented Turbo Blade

★★ Premium General Purpose  
Fast Cut/Longest Life Cured Concrete/Brick

Diameter & Width	Part No.	List
14" x .125" x 1"-20mm +DP	D41004	\$265
16" x .125" x 1"-20mm +DP	D41006	319

DRY/WET  
.472" segment height  
Laser Welded

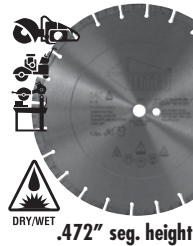

### U13ST Segmented Turbo Blade

★ General Purpose  
Fastest Cut/Good Life - Brick

Diameter & Width	Part No.	List
14" x .125" x 1"-20mm DP	D41030	\$125

DRY/WET  
.472" seg. height



### DX-T Wide Turbo Rim Blade

★ Economy, Fast Cut

Diameter & Width	Part No.	List
4" x .095" x 7/8" - 5/8"	D96209	\$21
4.5" x .095" x 7/8" - 5/8"	D96210	24
5" x .095" x 7/8" - 5/8"	D96224	30
7" x .095" x DM-7/8" - 5/8"	D96211	47
9" x .095" x 7/8" - 5/8"	D96225	78
10" x .110" x 7/8" - 5/8"	D96213	90
12" x .125" x 1" - 20mm DP	D96216	125
14" x .125" x 1" - 20mm DP	D96217	157

DRY/WET  
.275" seg. height



### D25 Ductile Iron

★★ Premium

Diameter & Width	Part No.	List
12" x .125" x 1"-20mm	D44001	\$233
14" x .125" x 1"-20mm	D44002	271
16" x .125" x 1"-20mm	D44005	379

DRY/WET  
.200" seg. height  
Laser Welded

# Slurry Flocc/Gel / Sprayers / Concrete Destroyer / Abrasives



SlurrySep Flocc Agent					A
Description	SlurrySep	List	SlurrySep-PH	List	
50-lb bag	100540	\$839	100541	\$1,164	
4 gallon bucket*	100543	453	100544	613	

SlurryDry Slurry Gel					A
Description	SlurryDry-QS	List	SlurryDry-LS	List	
50-lb bag	100539	\$1,164	100562	\$1,130	
4 gallon bucket*	100542	613	100563	595	

QS - Quick Solidification  
LS - Low Solids Slurries \* 4 gallon buckets weigh approximately 25 lb.



Pumps, Sprayer Pumps and Spigots			P
Description	Part No.	List	
Pump for 55 gallon drums	100328	\$100	
Sprayer Pump for Foaming Chemicals	100354	226	
Sprayer Pump, 3.5 gal.	151470	185	
Spigot for 5 gallon bucket	100323	6.49	

151470



High Speed Abrasive Blades					A
Dimensions	Grit	Application	Part No.	List	
12"x1/8"x1"		Metal	A30001	\$10.45	
12"x1/8"x20mm		Metal	A30002	10.45	
12"x1/8"x1"		Concrete	A30003	11.33	
12"x1/8"x20mm		Concrete	A30004	11.33	
12"x1/8"x1"	AC24R	Ductile	A30005	11.48	
12"x1/8"x20mm	AC24R	Ductile	A30006	11.48	
14"x5/32"x1"	C16T	Green Concrete/Asphalt	A30007	21.00	
14"x1/8"x1"		Metal	A30009	15.19	
14"x1/8"x20mm		Metal	A30010	15.19	
14"x1/8"x1"		Concrete	A30011	15.97	
14"x1/8"x20mm		Concrete	A30012	15.97	
14"x1/8"x1"	AC24R	Ductile	A30013	16.74	
14"x1/8"x20mm	AC24R	Ductile	A30014	16.74	

10 per box



Concrete Abrasive Blades					A
Dimensions	Grit	Application	Part No.	List	
14"x3/16"x1"	C24R	Concrete	A40001	\$27.00	
14"x3/16"x1"	C16T	Green Concrete/Asphalt	A40002	27.00	

10 per box



Cut/Off Abrasive Blades					A
Diameter & Width	Application	Part No.	List		
4-1/2"x3/32"x7/8"	Metal	A10003	\$4.12		
7"x3/32"xDM-5/8"	Metal	A10001	5.00		

25 per box



CONCRETE DESTROYER				
Description	Standard Formula Part No.	List	Foaming Formula Part No.	A List
32-oz. spray bottle*	100316	\$25	100335	\$35
1 gallon bottle**	100317	50	100336	58
5 gallon bucket	100318	239	100337	255
55 gallon drum	100319	2,158	100338	2,163

\* Packaged 2 boxes of 6 32-oz bottles (12 total per case)  
\*\* Packaged 4 one gallon bottles per case  
270 Gallon tote size is also available. Call for more information.



Raised Hub Abrasive Wheels					A
Diameter & Width	Application	Pack Qty.	Part No.	List	
4-1/2"x.045"x7/8"	Metal/ Stainless	25 per box	A00001	\$3.61	
4-1/2"x1/8"x7/8"	Metal/	25 per box	A00002	3.04	
4-1/2"x1/8"x5/8"-11	Metal	10 per box	A00003	6.54	
4-1/2"x1/4"x7/8"	Metal	25 per box	A00004	3.76	
4-1/2"x1/4"x5/8"-11	Metal	10 per box	A00005	7.21	
5"x1/8"x7/8"	Metal	25 per box	A00007	4.74	
5"x1/8"x5/8"-11	Metal	10 per box	A00008	8.24	
5"x1/4"x5/8"-11	Metal	10 per box	A00010	8.50	
7"x1/4"x5/8"-11	Metal	10 per box	A00014	10.45	



Cup Grinding Wheels					A
Diameter & Width	Application	Grit	Part No.	List	
4"x2"x5/8"-11 prong type	Concrete	C16R	A50002	\$36.00	
5"x2"x5/8"-11 prong type	Concrete	C16R	A50003	37.00	
6"x2"x5/8"-11 safety back	Concrete	C16R	A50004	42.00	

10 per box



Chop Saw Abrasive Blades					A
Diameter & Width	Application	Part No.	List		
12"x3/32"x1"	Metal	A20001	\$10.45		
14"x3/32"x1"	Metal	A20002	11.59		

10 per box

**Abrasive Wheels are priced individually and sold in whole box quantities only.**

# Carbide and Diamond Cup Grinding Wheels



**TEQ-ZEK wheels are made of silicon carbide and are aggressive and long lasting.**



Type 27

TEQ-ZEK Grinding Wheels			A
Description	Grit	Part No.	List
4.5" x 7/8"	16	160142	\$7.57
7" x 7/8"	16	160143	9.73

(priced each, packaged 5 per box) 8/10 and 24 grit also available  
5/8"-11 Adapter and nut (P/N 161779) \$15.45 (P)



Brazed Diamond Grinding Wheels					
A	Description	4.5"	List	7"	List
	Position 0 (25 Grit)	161027	\$126	161021	\$221
	Position 1 (30 Grit)	161028	108	161022	213
	Position 2 (40 Grit)	161029	100	161023	191
	Position 3 (50 Grit)	161030	100	161024	191
	Position 4 (100 Grit)	161031	100	161025	191
	Position 5 (200 Grit)	161032	100	161026	191



PCDC-35 and PCDC-39 Cup Wheels				
Description	No. of Chips	Part No.	List	D
PCDC-35 4" x 7/8" - 5/8"	5	D83201	\$199	
PCDC-35 4" x 5/8" - 11	9	D83203	149	
PCDC-35 5" x 5/8"-11	12	D83205	189	
PCDC-39 7" x 7/8" - 5/8"	9	D83202	399	
PCDC-39 7" x 5/8" - 11	18	D83204	299	



CS14, CD14 Cup Grinding Wheel				
★ Standard				
Description	CS14		CD14	
	Single Row	D List	Double Row	D List
4" x 7/8"-5/8"	D80001	\$48	D80006	\$76
4" x 5/8"-11 thread	D80002	48	D80007	76
4.5" x 7/8"-5/8"	D80025	65	D80026	92
4.5" x 5/8"-11	D80029	65	D80030	92
5" x 7/8"-5/8"	D80003	92	D80008	108
5" x 5/8"-11 thread	D80023	92	D80024	108
7" x 7/8"-5/8"	D80004	103	D80009	146
7" x 5/8"-11 thread	D80005	103	D80010	146



CS33, CD33 Cup Grinding Wheel				
★★★ Super Premium				
Description	CS33		CD33	
	Single Row	D List	Double Row	D List
4" x 7/8"-5/8"	D80011	\$87	D80016	\$141
4" x 5/8"-11 thread	D80012	87	D80017	141
4.5" x 7/8"-5/8"	D80027	103	D80028	163
4.5" x 5/8"-11	D80031	103	D80032	163
5" x 7/8"-5/8"	D80013	119	D80018	178
5" x 5/8"-11 thread	D80033	119	D80034	178
7" x 7/8"-5/8"	D80014	178	D80019	276
7" x 5/8"-11 thread	D80015	178	D80020	276



Segmented Storm Cup Wheel				
CST24 ★★ Premium				
CST34 ★★★ Super Premium				
Description	CST24	List	CST34	List
4" x 7/8"-5/8"	D81037	\$108	D81019	\$146
4" x 5/8"-11 thread	D81038	108	D81020	146
4.5" x 7/8"-5/8"	D81039	125	D81021	163
4.5" x 5/8"-11 thread	D81040	125	D81022	163
5" x 7/8"-5/8"	D81041	146	D81023	190
5" x 5/8"-11 thread	D81042	146	D81024	190
7" x 7/8"-5/8"	D81043	195	D81025	298
7" x 5/8"-11 thread	D81044	195	D81026	298



Segmented Turbo Cup Grinding Wheels				
CST13 ★ Standard				
CST23 ★★ Premium				
Description	CST13	List	CST23	List
4" x 9-10 seg x 7/8"-5/8"	D81047	\$55	D81001	\$92
4" x 9-10 seg x 5/8"-11	D81035	55	D81002	92
4" x 18 seg x 5/8"-11	D81049	81	D81058	138
4.5" x 9-10 seg x 5/8"-11	D81051	60	D81028	98
5" x 12 seg x 5/8"-11			D81003	113
7" x 12 seg x 7/8"-5/8"	D81034	90	D81004	135
7" x 12 seg x 5/8"-11	D81036	98	D81005	135
7" x 24 seg x 7/8"-5/8"	D81055	157	D81008	216
7" x 24 seg x 5/8"-11	D81056	157	D81009	216



CTC32 Continuous Turbo Cup					
★★★ Super Premium					
Description	Part No.	Fine	Medium	Coarse	List
		100/120	60/80	30/40	
4" x 7/8"-5/8"	D82005	D82003	D82001		\$158
4" x 5/8"-11 th	D82006	D82004	D82002		158
5" x 7/8"-5/8"	D82017	D82015	D82013		169
6" x 5/8"-11 th	D82024	D82022	D82020		180
7" x 5/8"-11 th	D82030	D82028	D82026		300



Turbo HD		
★★★ Super Premium		
Description	Part No.	List
4" x 7/8"-5/8" 7 + 7 Seg	D81032	\$119
4" x 5/8"-11 7 + 7 Seg	D81045	119
7" x 7/8"-5/8" 9 + 9 Seg	D81033	254
7" x 5/8"-11 9 + 9 Seg	D81046	254



FTC32 Ceiling Grinding Plate		
★★★ Super Premium		
Description	Part No.	List
5" x 5/8"-11	160161	\$204
6" x 5/8"-11	160162	263



S22 Vacuum Brazed Grinding Wheels		
★★ Premium		
Description	Part No.	List
4" Coarse x 5/8"-11	D66039	\$148

# Grinding Wheels / TEQ-Grind / Dustless Vacuum Systems / Shrouds



## S-Segment Cup Wheel

### CST24 ★★ Premium

	CST24	CST34	D
Description	20 Grit	List 40 Grit	List
4" x 5/8"-11	D81075	\$108	D81079 \$88
5" x 7/8"-5/8"	D81076	180	
7" x 7/8"-5/8"	D81077	211	
7" x 5/8"-11	D81078	216	D81080 175



## Dustless Vacuum Systems

### Dustless Vacuum Specifications

	Std Vac	HEPA
Specifications	16 WD	
Inches Water Lift	72	
CFM	116	
Volts	110	
Watts	1324 peak	
Amps	11.5	
RPM's	23,000	
<b>Vac Only Part No.</b>	<b>160070</b>	<b>160071</b>
<b>List E</b>	<b>\$349</b>	<b>\$617</b>



## Arrowhead Cup Wheel

### ★★★ Super Premium

Description	Part No.	List	D
4" x 7/8"-5/8" + 5 Seg	D81065	\$98	
4" x 5/8"-11 + 5 Seg	D81066	100	
7" x 7/8"-5/8" + 10 Seg	D81071	168	
7" x 5/8"-11 + 10 Seg	D81072	168	

Additional sizes available upon request.

Accessories/Attachments	Part No.	List	E
WD Filter package wet/dry lifetime	160089	\$46	
WD Filter master pk (pkg. 5 Pri & Sec)	160090	209	
HEPA Filter	160074	192	
HEPA Filter cover	160233	35	E
Micro pre-filter bags (qty of 10 filter bags)	160072	104	
Micro pre-filter bags (qty of 20 filter bags)	160076	202	
Micro pre-filter bags (qty of 2 filter bags)	160123	26	
6' Hose 1-1/4" Diameter	160092	26	P
25' x 2" Flexible hose w/coupler	160093	147	P
Splitter, Y-2" x 2" x 2"	160105	16.48	P
"Y" hose stub (req'd with 160105)	160235	23	P
2" hose to 2" hose coupler	161107	8.65	P
2" Core Drill Shroud w/hose	160085	69	P
3" Core Drill Shroud w/hose	160086	87	
Turbo Carpet Tool	160154	114	



## TG5V / TG6V TEQ-Grind

Outside Dia. of Disc	TG5V 5"	TG6V 6"
Watt/AMPs	750W/7.5 AMPS	1200W/12AMPS
No load speed	2800-10500/min	2800-10000/min
Spindle	5/8"-11unc 7/8" arbor	5/8"-11unc 7/8" arbor
Weight	3.7 lbs	6.3 lbs
<b>Part No.</b>	<b>G30005</b>	<b>G30006</b>
<b>List E</b>	<b>\$98</b>	<b>\$149</b>

Accessories	Part No.	List	P
Replacement Brushes for TG5V	160109	\$3.24	
Replacement Brushes for TG6V	160110	\$4.33	

Sold in sets of 2



DITEQ dust shroud shown installed on TEQ-Grind

## DITEQ Saw Shrouds and Accessories

Description	Part No.	List	E
DITEQ Blue 5" Shroud 5" x 2" w/18" hose	160146	\$55	
DITEQ Blue 5" Shroud 5"x1-5/8"	160319	29	
DITEQ Blue 5" Shroud 5"x1-5/8" w 18" Hose	160145	55	
Ban clamp 1-5/8"	160320	3.24	P
DITEQ Blue 5" Shroud 5" x 2"	160219	33	
Ban clamp 2"	160253	3.24	P
DITEQ Blue 5" Shroud 5x1-5/8" w/18" Hose/cover	160165	70	
Adapter Extender Blade 5/8-11"-11F x 7/8" Bore	130117	18.54	
18" hose for DITEQ shrouds	160091	21	

## DustBuddie (clear) 5" 7" E

Description	Part No.	Part No.	List
DustBuddie w/18" hose	160242	160327	\$125
5" Cover Plate	160224	160328	14.06
18" Hose Connection	160091		21

## CutBuddie III E

Description	Part No.	List
5" CutBuddie w/18" hose	161781	\$163
7" CutBuddie w/18" hose	161782	200

## Dustie (grey) 5" 7" E

Description	Part No.	Part No.	List
Dustie	160321	160322	\$38.00
Cover Plate	160224	160328	14.06
18" Hose Connection	160091		21

## Saw Buddie E

Description	Part No.	List
Saw shroud	161863	\$90

## BitBuddie E

Description	Part No.	List
1-3/8" dia. bits w/hose	160220	\$53
1" to 4" dia. bits (round) w/hose	160979	53
2-8" dia. bits (round)	161625	61

# Dustless Vacuum Systems / Drywall Sanders



## Synchronized Tool/Vacuum System <sup>E</sup>

Description	Part No.	List
ToolSync set w/ 1 ea. VacPod and ToolPod	161443	\$243
VacPod	161441	128
ToolPod	161095	126

For wet use only.



Vacuum and motor unit shown mounted on 55 gallon metal drum (included)

## Dustless Wet/Slurry Continuous Duty Vacuums

VOLTS/Watts	120V/1,500
AMPS	13
Vacuum Pressure (H <sub>2</sub> O")	90"
Air Movement (CFM)	115
Inlet (in.)	2"
Capacity (gal)	55
Effective Slurry pickup distance	100 ft
Hose Included	25 ft x 2" diameter
Drum Liner	Optional
<b>PART No. Complete</b>	<b>100553</b>
<b>List E</b>	<b>\$3,426</b>
<b>Motor Head and Hose</b>	<b>100555</b>
<b>List E</b>	<b>\$2,350</b>

Accessories/Components		P
Description	Part No.	List
Cart, 55 gallon drum	100630	\$630
Vacuum Wand, slurry vac	100631	140
Motor brush set	100556	24
Filter, slurry vac	100558	68
Seal, slurry vac	100561	33



Turbo Drywall Sander <sup>E</sup>		
Description	Part No.	List
Turbo Drywall Sander	160069	\$195

PaintBuddie <sup>E</sup>		
Description	Part No.	List
2" PaintBuddie (includes 3 blades)	160141	\$35

Accessories/Attachments <sup>E</sup>		
Description	Part No.	List
1/2 oz oil bottle sander	160080	\$3.24
Multi pack - all grits 5 of ea. 25pk 100, 120, 150, 180, & 220 grits	160079	38
100 grit sandpaper 25 pack	160214	33
120 grit sandpaper 25 pack	160215	33
150 grit sandpaper 25 pack	160124	33
180 grit sandpaper 25 pack	160078	33
220 grit sandpaper 25 pack	160125	33



Dustless HEPA Backpack Vacuum	
VOLTS/Watts	120V/1,500
Volts	120
Amps	11
Decibels	77
Weight	11 lb.
Vacuum Pressure (H <sub>2</sub> O")	82"
Air Movement (CFM)	80
Capacity (gal)	2.5
Hose Included	5 ft
<b>PART No.</b>	<b>161626</b>
<b>List E</b>	<b>\$850</b>

Accessories - Dustless HEPA Backpack Vacuum <sup>P</sup>		
Description	Part No.	List
HEPA Filter 3 pack	161860	\$66
Filter Sock	161861	36
Harness	161862	75

Specifications	DUST DROID For Extra Fine Dust	
	Single Motor 300 Vac	Dual Motor 600 Vac
Hepa Rated	99.97%	99.97%
Motor	one 2 hp	dual 2 hp
Volts	120v / 50-60 hz	120 or 240v / 50-60 hz
Watts/AMPS	1560 / 13	3120 / 13 (ea)
Vacuum Pressure (H <sub>2</sub> O")	90 in.	90 in.
Air Movement (CFM)	300	600
Inlet (in.)	2"	3"
Capacity (gal)	20	30
Hose (included)	2" X 25'	3" X 25'
<b>PART No.</b>	<b>161584</b>	<b>161682</b>
<b>List E</b>	<b>\$8,034</b>	<b>\$9,800</b>

Accessories	Droid 300		Droid 600		P List
	Part No.	Price	Part No.	List	
Bags - pack of 100	161874	\$290	161864	\$380	
Bags - pack of 10	161875	38	161865	40	



# Industrial Vacuums and Rideable Scrubber



Shown with wand kit  
Comes standard with 16 ft. of 2 inch Hiloflex hose

Dual Motor Dry Vacuum	
Vacuum Pressure (H <sub>2</sub> O")	110"
Air Movement (CFM)	180
Filtration at 99.55%	.5 micron
Sound Level	67 dB(A)
Weight	50 lb.
Capacity (gal)	12
<b>PART No.</b>	<b>160799</b>
<b>List E</b>	<b>\$1,735</b>

Accessories for Dual Motor Dry Vacuum		
Description	Part No.	List P
5 Pack Hepa-Flo Bags (large - 4B)	160814	\$112
10 Pack economy bags (large)	160839	58
Optional HEPA Assembly	160812	839
HEPA Replacement Element	160817	405
"Y" Connector	160815	112
Wand Kit	160801	234
Replacement Hose - 15 ft. Hiloflex	160813	206
29" Mounted Brush Attachment	160818	299



Shown with optional wand kit  
Comes standard with 15 ft. of 2 inch Hiloflex hose

Single Motor Dry, Fine Dust Vacuum	
Motor	Single, 1.6 hp, 1200 Watts
Airflow	95 cfm
Inches Water Lift	100"
Capacity	5 gallons
Hose	15' two inch diameter Hiloflex
Sound Level	64 dB(A)
Weight	36 lb.
Standard Filtration	.3 micron @ 99.6% efficiency
Part No.	<b>160800</b>
<b>List E</b>	<b>\$964</b>

Accessories for Single Motor Dry Vacuum		
Description	Part No.	List P
5 Pack Hepa-Flo Bags (Small 3B)	160816	\$106
10 Pack economy bags (small)	161554	52
HEPA Assembly	160812	839
Wand Kit	160801	234
Replacement Hose - 15 ft. Hiloflex	160813	206



Shown with 29" mounted squeegee P/N 160802

Wet Slurry Clean-up Vacuum				
Pickup Unit	29" mounted squeegee kit	w/Wand	w/Wand	29" mounted squeegee kit
Motor	Single 2 stage,	Single 2 stage	Single 2 stage	Single 2 stage
Power	1.6 hp, 1200 Watts	1.6 hp, 1200 Watts	1.6 hp, 1200 Watts	1.6 hp, 1200 Watts
Speed	Single	Single	Single	Single
Airflow	95 cfm	95 cfm	95 cfm	95 cfm
Inches Water Lift	110"	110"	110"	110"
Tank Capacity (gallons)	12	12	20	20
Power Cord	42' in length	42' in length	42' in length	42' in length
Sound Level	64 dB(A)	64 dB(A)	64 dB(A)	64 dB(A)
Weight	44 lb.	52 lb.	70 lb.	70 lb.
Tank & Head	Structural foam	Structural foam	Structural foam	Structural foam
Part No.	160802	160825	161552	160838
<b>List E</b>	<b>\$1,071</b>	<b>\$1,022</b>	<b>\$1,136</b>	<b>\$1,190</b>

Optional Accessories		
Description	Part No.	List E
Squeegee Wand Kit w/10' Hose	160824	\$243
Dry filter (not for fine dust)	160829	149



TWINTEC Vario One Machine - Three Scrubbing Widths	
Cleaning Path	26", 30", 34"
Pad or Brush Size	3 x 12"
Solution/Recovery Tank	32 gal.
Chemical Capacity	1 gal.
Chemical Mixture Rates	32:1, 64:1, 96:1, 128:1
Water Flow Rate	1.0 / 0.8 / 0.5 / 0.25 gpm
Brush Pressure	160 lbs. max
Brush Speed	125-200 rpm
Brush Motor	3 x 24V, 400W
Traction Motor	600W
Working Speed	0.3 - 4.3 mph
Maximum Gradient	11°
Vacuum Motor Power	24V, 400W
Noise Level	67 dB(A)
Working Capacity (sq. ft./hr.)	59,800 sq. ft./hr.
Run Time	4 hrs.
Batteries (gel)	6 x 12V, 100 Ah.
Weight (including batteries)	850 lbs.
Dimensions (LxWxH)	66" x 26" x 56"
Part No.	G00056
<b>List E</b>	<b>\$24,763</b>



**2**  
YEAR  
WARRANTY

<b>C-TEQ Crack Chasing Saw</b>			
<b>POWER</b>	<b>13.5HP</b>	<b>22HP</b>	<b>22HP</b>
Engine	Subaru	Subaru	Subaru
RPM	5400	5400	5400
Overall Width	24"	30"	30"
Overall Length (including handle)	53"	53"	53"
Handle Height	42" to 51"	42" to 51"	42" to 51"
Blade Depth	0 to 1-1/2"	0 to 1-1/2"	0 to 1-1/2"
Weight	250 lb.	450 lb.	450 lb.
Blade Capacity	6"	6"	6"
Suggested Blade Width	1/4"-3/8"	1/4"-3/4"	1/4"-3/4"
Model No.	C-TEQ 135S	C-TEQ 220	C-TEQ 220A
<b>Part No.</b>	<b>F40002</b>	<b>F40003</b>	<b>F40007*</b>
<b>List Price E</b>	<b>\$7,565</b>	<b>\$9,728</b>	<b>\$9,728</b>

*\* For use on asphalt*

## C31/A34 Crack Repair Blades for C-TEQ Saw

★★★ Super Premium

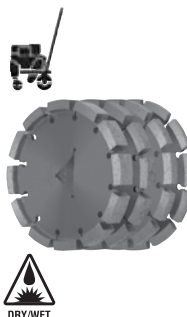

<b>Dia. &amp; Width</b>	<b>C31</b>	<b>A34</b>	<b>D List</b>
	<b>Concrete</b>	<b>Asphalt</b>	
6" x .250"	D22401	D22402	\$190
6" x .375"	D22403	D22404	298
6" x .500"	D22405	D22406	379
6" x .750"	D22407	D22408	514

*Z-Arbor for C-TEQ Crack Chasing Saw only.*

## Carbide-Edge Routing Cutters/ Crack Chasers

<b>No. of Teeth</b>	<b>O.D.</b>	<b>I.D.</b>	<b>Thickness</b>	<b>Part No.</b>	<b>A List</b>
7	4.84"	1.00"	.36"	160805	\$73
7				161786	99

*More sizes available upon request!*

<b>Accessories</b>			<b>P</b>
<b>Description</b>	<b>Part No.</b>	<b>List</b>	
Hardened spacer	161777	\$1.03	
Pin 7/8" Dia x 4-1/4" L	161776	8.76	



## CR C35 Beveled V-Crack Chaser

★★★ Super Premium



<b>Diameter &amp; Width</b>	<b>Part No.</b>	<b>D List</b>
4" x cont. type x 5/8"-11 thrd	D90001	\$211
4 x .375" x 5/8"-11	D90008	157
4" x .375" x 7/8"-5/8"	D90002	146
5" x .375" x 7/8"-5/8"	D90003	184
7" x .375" x 7/8"-5/8"	D90004	298
8" x .375" x 1"	D90005	471

# Surface Prep / TG8 Grinder / Polisher / Tools

## TG8 Grinder Polisher

Motor	2hp	2 hp	5.5 Honda	5.5 Subaru
Phase	Single	Single	Gas	Gas
Full Load AMPS @115V	18.4	18.4	GXV160	EA190
RPM - Disc	2800	Variable 0 - 2800	2800	2800
Model	FGE 2L	FGEP2L	FGG 5H	FGG5S
Weight	130 lbs	130 lbs	120 lbs	120 lbs
<b>Part No. w/Grinding Plate</b>	<b>G00046</b>	<b>G00047</b>	<b>G00048</b>	<b>G00072</b>
<b>List E</b>	<b>\$3,239</b>	<b>\$3,790</b>	<b>\$3,564</b>	<b>\$3,264</b>
<b>Part No. w/TEQ-Lok Plate</b>	<b>G00057</b>	<b>G00060</b>	<b>G00058</b>	<b>G00073</b>
<b>List E</b>	<b>\$3,111</b>	<b>\$3,662</b>	<b>\$3,435</b>	<b>\$3,135</b>

*Grinding disc is D91003 TEQ-Lok plate is 160222  
Standard rotation is RH (right hand)*

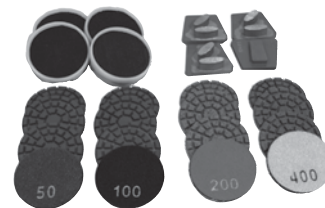

Standard TG8 Grinding Tools/Accessories				D
Diameter & Width	Seg	Grit	Part No.	List
FGG34 8" x 3/4" (std bond)	10	Coarse - 30/40	D91003	\$589
FGP35 8" x 3/4" (std bond)	10	Med - 60/80	D91005	589
FGG36 8" x 3/4" (hard bond)	10	Coarse - 30/40	D91009	589
FGG34 8" x 3/4" (std bond)	5	Coarse - 30/40	D91006	536

*\*includes rubber isolator 161113*

2" Velcro Backed TEQ-Lok Starter Polishing Kit for 8" TG8*		
Description	Qty	Part No.
Velcro Driver (4)	4	161165
50 Grit (4)	4	161163
Semi-Metal 50 Grit (4)	4	161167
Semi-Metal 100 Grit (4)	4	161168
Dry Resin 200 Grit (4)	4	161172
Dry Resin 400 Grit (4)	4	161173
<b>Polishing Kit (4 of each above part)</b>		<b>161245</b>
<b>List A</b>		<b>\$1,453</b>

*\*Typically follows a 30G grinding step.*

**See Page 35 for full line of TEQ-Lok Tools**

# TG12 and TG18 Grinder/Polishers



<b>TG12 Grinder/Polisher</b>			
Disc Size	12"	12"	12"
Horsepower/RPM	5 / 1000	3 HP / Variable 0 - 1000	11 HP Gas / 1000
Engine/Motor	220V, 1 PH	220V 1 PH	Honda
Amps	23	8.4	N/A
Height	41"	41"	41"
Length	32"	32"	32"
Width	18"	18"	18"
Weight	220 lb.	200 lb.	200 lb.
<b>Part No.</b>	<b>G00051</b>	<b>G00054</b>	<b>G00055</b>
<b>List E</b>	<b>\$4,321</b>	<b>\$4,537</b>	<b>\$4,645</b>

*Other power options available.*

<b>Polishing Kits for TG12 Grinder</b>		
<b>Full Diamond TEQ-Lok and 3" Resin Polishing Kit*</b>		
Description	Qty.	Part No.
Diamond Button Medium 60/80 Grit	3	D91105
TEQ-Lok 3" Velcro Pad Driver	3	160969
Dry 3" Resin pad, 50 Grit	3	160907
Dry 3" Resin pad, 100 Grit	3	160908
Dry Resin pad 200 Grit	3	160909
Dry Resin pad 400 Grit	3	160910
<b>Polishing Kit (3 of each above part)</b>		<b>161531</b>
<b>List A</b>		<b>\$1,181</b>

*\* Typically follows a 30G grinding step*

<b>TG18 Grinder / Polisher</b>					
Specifications	Grinder	Grinder	Grinder	Grinder / Polisher	Grinder
Disc Size	18"	18"	18"	18"	18"
Horsepower / RPM	5	5	5	3	11 hp Gas
Engine / Motor	220V / 1 PH	240V / 3 PH	480V / 3 PH	Variable/220 1 PH	Honda
Amps	23	14	6.6	8.4	N/A
Height	37"	37"	37"	37"	37"
Length	56"	56"	56"	56"	56"
Width	25"	25"	25"	25"	25"
Weight	290 lb	295 lb	295 lb	295 lb	280 lb
<b>Part No.</b>	<b>G00066</b>	<b>G00067</b>	<b>G00068</b>	<b>G00069</b>	<b>G00070</b>
<b>List Price E</b>	<b>\$4,641</b>	<b>\$4,965</b>	<b>\$4,965</b>	<b>\$4,857</b>	<b>\$4,965</b>

*TEQ-Lok plate is included*



TG18 can use TEQ-Lok tools or cup wheels

# Production Grinder/Polishers / Scarifier Accessories

## G & P One Planetary Production Grinder / Polisher

### Specifications:

<b>Disc Size</b>	<b>30"</b>
Production	800-1300 sf per hour
Horsepower/RPM	22 / 3200
Engine	Robin/Propane
Height	55"
Length	80"
Width	38"
Weight	1,385 lb.
<b>Part No.</b>	<b>G00045</b>
<b>List E</b>	<b>\$36,771</b>



## LX-30 Planetary Grinder / Polisher

### Specifications:

Production	800-900 sq ft per hr
Engine	Robin 22 hp / propane
Engine Speed	3,200 rpm
Drum Speed	1,410 rpm
Head Speed	840 rpm
Grinding Pressure	500 lbs.
Grinding Diameter	28 inches
Box Dimensions	L80"xW38"xH55"
Shipping Weight	950 lb.
<b>Part No.</b>	<b>G00050</b>
<b>List E</b>	<b>\$27,913</b>

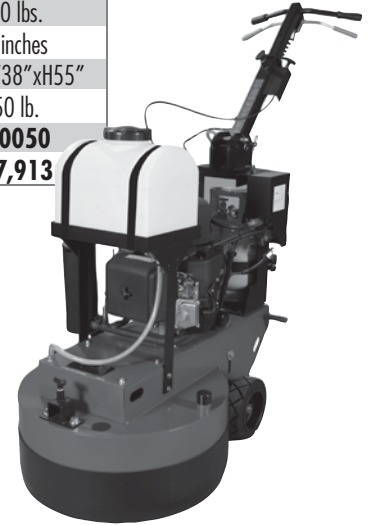

## Scarifier Drum Assemblies, Spacers and Cutters



Scarifier Drum Assemblies Description	Std.	Total No.	Part No.	A List
Drum Assembly w/8 pt tungsten carbide cutters (complete)	160379	160919	160970	<b>\$2,153</b>
	66 cutters/75 spacers			
Drum Assembly w/8 pt FF tungsten carbide cutters (complete)	160351	160919	160995	<b>3,130</b>
	66 cutters/75 spacers			
Drum Assembly w/pointed steel cutters (complete)	160334	160918	160996	<b>1,349</b>
	111 cutters/111 spacers			
Drum Assembly w/milling cutters (complete)	160358	160920	161116	<b>1,982</b>
	24 cutters/33 spacers			

Scarifier Shafts and Spacers	Part No.	A List
1/2" diameter x 10-5/8" shaft	160182	<b>\$9.73</b>
1/2", Thin Hardened Spacer	160918	<b>.30</b>
1/2", Thick Hardened Spacer	160919	<b>1.08</b>
1/2", Small-Thick Hardened Spacer	160920	<b>.38</b>

*Drums and shafts are available for many brands and models of scarifiers. Call customer service for information and pricing.*

## Cutters for Scarifiers

Type	No. of Teeth	OD (in)	ID (In)	Thickness (in)	Part No.	A List
Star, Steel	18	1.250	0.438	0.188	160347	<b>\$2.16</b>
Star, Steel	18	2.000	0.500	0.188	160342	<b>2.16</b>
Star, Steel	18	2.000	0.500	0.156	160343	<b>2.16</b>
Star, Steel	18	2.000	0.750	0.156	160334	<b>2.43</b>
TCT Flail	6	1.750	0.625	0.250	160203	<b>14.06</b>
TCT Flail	8	2.250	0.750	0.250	160379	<b>22.00</b>
TCT Flail	8	2.250	1.000	0.250	160380	<b>22.00</b>
TCT Full Face Flail	8	2.250	0.625	0.250	160350	<b>43.00</b>
TCT Full Face Flail	8	2.250	0.750	0.250	160351	<b>43.00</b>

*DITEQ carries a full line of carbide cutters. This is just a sampling of the most commonly used cutters. Call customer service for recommendation.*

## CPM8 Cutter Package

Description	Qty	Part No.
TCT Cutter - 6T-44 x 16 x 6	78	160203
Hardened Spacer, 1/2", small thick	215	160920
Shaft for Spacers, 1/2 x 8-9/16"	6	160988
<b>CPM8 Cutter Package</b>		<b>161434</b>
<b>List A</b>		<b>\$1,226</b>

# TEQ-Lok Tools / Surface Prep Grinding Tools

## TEQ-Lok Tools for All Machines Using TEQ-Lok System



PCD TEQ-Lok Segments		
Description	Part No.	D List
PCDS - 1 whole round per seg - RH	161788	\$271
PCDS - 1 whole round per seg - LH	161642	271
PCD Segment (PCDS - 2 chips per seg) - RH	D91101	226
PCD Segment (PCDS - 3 chips per seg) - RH	D91102	284

TEQ-Lok System		
Description	Part No.	P List
8" TEQ-Lok Adapter Plate w/o segments	160222	\$197
12" TEQ-Lok Adapter Steel Plate w/o segments	160223	328
TEQ-Lok 2" velcro pad driver	161165	47
TEQ-Lok 3" velcro pad driver	160969	60
Replacement plastic ring for 2" pad driver	161621	18.54
Replacement velcro for 2" pad driver	161622	1.35
Placement plastic ring for 3" pad driver	161451	24
Replacement velcro for TEQ-Lok 3" pad driver	161452	2.16



TEQ-Lok Diamond Segment Coating Stripper		
Description	Part No.	D List
Diamond Segment (30/40) Grit	D91107	\$131



Carbide Scraping Mounting Block and Chips		
Description	Part No.	List
TEQ-Lok Carbide Mounting Block (RH)	161641	\$103.00 P
TEQ-Lok Carbide Mounting Block (LH)	161704	103.00 P
Low Profile Flathead Steel Mounting Screw	900138	1.63 P
Carbide Replacement Chip - 8 sided	160309	30.00 A

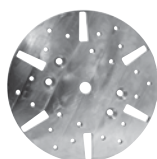

Adapter Description*		
Description	Part No.	P List
10" TEQ-Lok Plate w/o segments	161638	\$556

(\*10" x 3/4" x 3/8"-24 threads) (Universal bolt pattern fits most single-head grinders)



TEQ-Lok Twin Full Rectangular Segments				
Description	Bond	Part No.	D List	
16/18 Grit	Hard	D91118	\$102	
16/18 Grit	Extra Hard	D91119	102	
20/25 Grit	Medium	D91103	102	
30/40 Grit	Medium	D91104	102	



Metal Bond Diamond TEQ-Lok Mini Segments				
Description	Part No.	A List		
16 Grit	161238	\$181		
30 Grit	161162	159		
50 Grit	161163	159		
80 Grit	161164	159		



TEQ-Lok Twin Round Segments					
Description	Soft Bond	Medium Bond	Hard Bond	Extra Hard Bond	D List
16 Grit	D91110	D91108	D91117		\$102
30 Grit	D91111	D91109	D91112	D91120	102
60 Grit	D91115	D91105	D91113		102
120 Grit	D91116	D91106	D91114		102

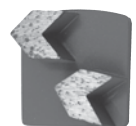

TEQ-Lok Arrowhead Segments				
Description	Soft Bond Part No.	Med Bond Part No.	Hard Bond Part No.	A List
16 Grit	161975	161978	161981	\$90
30 Grit	161976	161979	161982	90
60 Grit	161977	161980	161983	90



Standard 10" Diameter Floor Grinding Heads and Adapters		
Grinding Head Description	Part No.	D List
FGG25 20 Segments FG (coarse grit)	D91001	\$536
FGG15 10 Segments FG	D91002	351



Diamond Blocks				
Description	Soft Bond Part No.	Med Bond Part No.	Hard Bond Part No.	D List
30/40 Grit	161462	161457*	161461	\$195
40/50 Grit	161463			195
50/60 Grit	161464			195
80/100 Grit	161465			195
PCD Block (4 chips)	161555			366
Wedge	160178			1.03

\*general purpose



Abrasive Stones			
Dimensions	Grit	Part No.	A List
6" x 3" x 1" w/handle	C24	A50005	\$35.00
2" x 2" x 4" w/wedges	C10	A50006	13.39
2" x 2" x 4" w/wedges	C16	A50007	13.39
2" x 2" x 4" w/wedges	C24	A50008	13.39
Wedge		160178	1.03

Blocks are priced singularly and sold in whole box quantities only. 6 per box



# Surface Prep Tools



Brazed Lippage Pads		2"		3"		4"		5"		A
Grit	Part No.	List	Part No.	List	Part No.	List	Part No.	List	Part No.	List
24			160997	\$153	160989	\$181	160980	\$204		
30	161603	\$78	160934	142	160990	153	160981	171		
50	161604	76	160935	126	160991	153	160982	171		
100	161605	76	160936	108	160992	142	160983	159		
200	161606	76	160937	108	160993	142	160984	159		
325			160938	108	160994	142	160985	159		

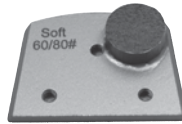

Single Round Dovetail Trapezoids					A
Grit	Soft Bond	Med Bond	Hard Bond	List	
18/20	161903	161908	161913	\$77	
25	161904	161909	161914	77	
35/40	161905	161910	161915	52	
60/80	161906	161911	161916	52	
120	161907	161912	161917	52	

Double Round Dovetail Trapezoids					A
Grit	Soft Bond	Med Bond	Hard Bond	List	
18/20	161918	161923	161928	108	
25	161919	161924	161929	108	
35/40	161920	161925	161930	82	
60/80	161921	161926	161931	82	
120	161922	161927	161932	82	

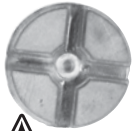
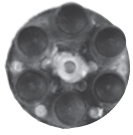

Resin Polishing Pads 60mm/2.4" Diameter				D
Grit	Post Part No.	Wedge Part No.	List	
50	161706	161713	\$36	
100	161707	161714	36	
200	161708	161715	36	
400	161709	161716	36	
800	161710	161717	36	
1500	161711	161718	36	
3000	161712	161719	36	



General Purpose QCS							A
Grit	Single Segment		Double Segment			List	
	Soft Bond	List	Soft Bond	Medium Bond	Hard Bond		
16/20	161753	\$77	161756	161761	161766	161771	\$108
30/40	161754	52	161757	161762	161767	161772	82
60/80	161755	52	161758	161763	161768	161773	82



Super Premium Trapezoid Segments					A
Grit	Hard Bond	Med Bond	Soft Bond	List	
	Soft Concrete	Medium Concrete	Hard Concrete		
6	160887	160888	160889	\$109	
14/16	160890	160891	160892	109	
30/40	160893	160314	160895	99	
60/80	160896	160315	160898	85	
120/150	160899	160316	160901	83	
220/300	160902	160903	160904	83	



Super Premium Trapezoid Round Segments					A
Grit	Hard Bond	Med Bond	Soft Bond	List	
	Soft Concrete	Medium Concrete	Hard Concrete		
6	160869	160870	160871	\$109	
14/16	160872	160873	160874	109	
30/40	160875	160876	160877	99	
60/80	160878	160879	160880	85	
120/150	160881	160882	160883	83	
220/300	160884	160885	160886	83	



Double Round Segment General Purpose QCS						A
Grit	Soft Bond		Medium Bond		Hard Bond	List
	Soft	Medium	Hard	Hard		
120/150	161759	161764	161769	161774	\$82	
250/300	161760	161765	161770	161775	82	



Standard/General Purpose Trapezoid Segments			A
Grit	Part No.	List	
18/20	161571	\$79	
30/40	161572	59	
60/80	161573	59	
120/150	161574	59	



PCD Trapezoid Grinding Segments				A
Description	Super Premium		List	
	Part No.	Part No.		
PCD-2 with 30 Grit Dia Seg Wear Bar		161192	\$278	
PCD-1 Whole w/Wear Button (Rt Hand)		161043	352	
PCD-1 Whole w/Wear Button (Lt Hand)		161450	341	
PCD-1 Whole w/Wear Button (Rt Hand)	161575		281	
PCD-1 Whole w/Wear Button (Lt Hand)	161829		281	

PCD Dovetail Trapezoid Grinding Segments						A
RH	LH	List	RH		List	
			w/Wear Bar	LH		
162001	162002	\$220	162003	162004	\$220	

RH - Right Hand LH - Left Hand Wear bar is 30 grit diamond segment



# Concrete Polishing Pads and Rings

### Diamond Sanding Pads

Grit	5"		7"		A
	Part No.	List	Part No.	List	
50	160633	\$77	161882	\$140	
70	160634	77	161883	140	
120	160635	65	161884	110	
220	160636	60	161885	95	
400	161880	52	161886	90	
600	161881	52	161887	90	

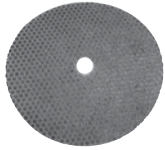

### Foam Cushion Pads

Description	Part No.	List	P
3" Foam Floating pads	161016	\$12.36	
5" Foam Floating pads	160632	24.00	

*Other sizes available*



### 2" Semi-Metal Velcro Backed Pads

Grit	Part No.	List	A
30	161166	\$45	
50	161167	45	
100	161168	45	
200	161588	45	
400	161590	45	



### 2" Resin Velcro Backed Pads

Grit	DRY		WET Only		A
	Part No.	List	Part No.	List	
30	161169	\$35			
50	161170	35			
100	161171	35			
200	161172	35	161696	35	
400	161173	35	161697	35	
800	161174	35	161698	35	
1500	161175	35	161700	35	
3000	161176	35	161701	35	



### 3" Metal Sintered Polishing Pads

Grit	WET/DRY		WET Only		A
	Part No.	List	Part No.	List	
6	161045	\$281			
16	161046	281			
30	161047	281	161017	\$191	
50	161048	281	161018	191	
70	161049	281	161019	191	
120	161050	281	161020	191	



### Metal Grinding Segments

Grit	Center Tap		Counter-Sunk*		List	D
	Part No.	List	Part No.	List		
16 (5 seg.)	161720		161725	\$185		
30 (10 seg.)	161721		161726	155		
70 (10 seg.)	161722		161727	155		
120 (10 seg.)	161723		161728	155		
220 (10 seg.)	161724		161729	155		

\*with pin



### 5" Super Premium Copper Pads

Grit	Part No.	List	A
30	160915	\$96	
50	160916	96	
100	160917	96	
200	162006	96	

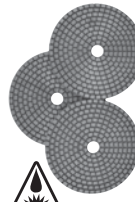

### 5" Resin Polishing Pads

Grit	Super Premium		Premium		A
	WET/DRY	List	WET/DRY	List	
50	160282	\$68	161654	\$52	161664 \$38
100/120	160283	68	161655	52	161665 38
200/220	160284	68	161657	52	161667 38
400	160285	68	161658	52	161668 38
800	160286	68	161660	52	161670 38
1500/1800	160288	68	161661	52	161671 38
3000/3500	160289	68	161662	52	161672 38
Buff			161663	52	161673 38



### 3" Concrete Resin Polishing Pads

Grit	Super Premium		Premium		List	A
	WET/DRY	List	WET/DRY	List		
30	160906	\$56	161643	\$45		
50	160907	56	161644	45	130341	\$39
100	160908	56	161645	45	130342	39
200	160909	56	161647	45	130343	39
400	160910	56	161648	45	130344	39
800	160912	56	161650	45	130345	39
1500	160913	56	161651	45	130346	39
3000	160914	56	161652	45	130347	39
Buff			161653	45		



### "Ceramic" Pads and Rings

Description	5" Pad		7" Ring		List	A
	Very Hard Concrete	Very Hard Concrete	Very Hard Concrete	Very Hard Concrete		
C1	161157		161150		\$96	
C2	161158		161151		91	
C3	161159		161152		91	
C4	161160		161153		91	

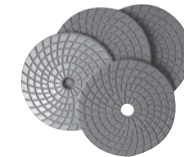

### 3" Concrete Metal Resin Polishing Pads

Grit	WET/DRY		List		A
	Part No.	List	Part No.	List	
30	161012	\$84	130370	\$52	
50	161013	84	130371	52	
100	161014	84	130372	52	
200	161015	84	130373	52	
400	161992	84	130374	52	



### 7" Super Premium Wet/Dry Velcro-backed Resin Rings

Grit	Part No.	List	A
30	161034	\$84	
50	161035	84	
120	161036	80	
220	161037	80	
400	161038	80	
800	161039	80	
1800	161040	80	
3000	161041	80	

# TEQ-Swing / TEQ-Burnisher / Burnisher Pads



17" TEQ-Swing Machine	
Gears	Triple Planetary
Weight	90 lb.
Pad Width	17"
Motor Power	1.5HP AC
Motor RPM	175
Part No.	G00038
List <b>E</b>	<b>\$1,076</b>



20" TEQ-Burnisher	
Gears	Belt Drive
Weight	112 lbs
Brush Width	20"
Brush Motor Power	1.5 hp DC Rectified
Brush RPM	1500
Part No.	G00039
List <b>E</b>	<b>\$1,839</b>

Optional Accessories	Part No.	List <b>P</b>
Maintenance Pad Driver	161436	<b>\$173</b>
17" Rigid Plate	161415	<b>167</b>
2 gallon solution tank kit	161435	<b>220</b>
Poly scrub brush	161437	<b>191</b>
Poly shampoo brush	161583	<b>191</b>

Accessories	Part No.	List <b>P</b>
20" Rigid Plate	161414	<b>\$178</b>

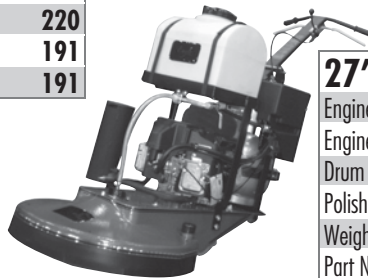

27" Production Burnisher	
Engine	Robin 22 hp
Engine Speed	3,450 rpm
Drum Speed	800-1000 rpm
Polishing Diameter	27"
Weight	350 lbs
Part No.	G00044
List <b>E</b>	<b>\$7,980</b>



## VL Burnisher Pads

VL M Series	13"		17"		20"		21"		24"		27"		A
Grit / Color	Part No.	List	Part No.	List	Part No.	List	Part No.	List	Part No.	List	Part No.	List	List
200 Blue	161837	<b>\$99</b>	161476	<b>\$125</b>	161483	<b>\$146</b>	161490	<b>\$154</b>	161556	<b>\$189</b>	161497	<b>\$231</b>	
400 Red	161838	<b>99</b>	161477	<b>125</b>	161484	<b>146</b>	161491	<b>154</b>	161557	<b>189</b>	161498	<b>231</b>	
800 White	161839	<b>87</b>	161478	<b>111</b>	161485	<b>127</b>	161492	<b>136</b>	161558	<b>165</b>	161499	<b>203</b>	
1500 Yellow	161840	<b>87</b>	161479	<b>111</b>	161486	<b>127</b>	161493	<b>136</b>	161559	<b>165</b>	161500	<b>203</b>	
3000 Green	161841	<b>87</b>	161480	<b>111</b>	161487	<b>127</b>	161494	<b>136</b>	161560	<b>165</b>	161501	<b>203</b>	
8000 Orange	161842	<b>87</b>	161481	<b>111</b>	161488	<b>127</b>	161495	<b>136</b>	161561	<b>165</b>	161502	<b>203</b>	
11000 Purple	161843	<b>87</b>	161482	<b>111</b>	161489	<b>127</b>	161496	<b>136</b>	161562	<b>165</b>	161503	<b>203</b>	



## Vortex Burnisher Pads

M Series	13"		17"		20"		21"		24"		27"		A
Grit / No.	Part No.	List	Part No.	List	Part No.	List	Part No.	List	Part No.	List	Part No.	List	List
800 #1	161253	<b>\$98</b>	161256	<b>\$163</b>	161257	<b>\$184</b>	161258	<b>\$195</b>	161824	<b>\$206</b>	161259	<b>\$271</b>	
1500 #2	161261	<b>98</b>	161264	<b>163</b>	161265	<b>184</b>	161266	<b>195</b>	161825	<b>206</b>	161267	<b>271</b>	
3000 #3	161269	<b>98</b>	161272	<b>163</b>	161273	<b>184</b>	161274	<b>195</b>	161826	<b>206</b>	161275	<b>271</b>	

R Series	13"		17"		20"		21"		24"		27"		A
Grit / Color	Part No.	List	Part No.	List	Part No.	List	Part No.	List	Part No.	List	Part No.	List	List
400 Orange	161293	<b>\$146</b>	161295	<b>\$206</b>	161296	<b>\$254</b>	161297	<b>\$298</b>	161298	<b>\$314</b>	161299	<b>\$401</b>	
800 Silver	161301	<b>146</b>	161303	<b>206</b>	161304	<b>254</b>	161305	<b>298</b>	161306	<b>314</b>	161307	<b>401</b>	
1800 Blue	161309	<b>146</b>	161311	<b>206</b>	161312	<b>254</b>	161313	<b>298</b>	161314	<b>314</b>	161315	<b>401</b>	
3000 Red	161317	<b>146</b>	161319	<b>206</b>	161320	<b>254</b>	161321	<b>298</b>	161322	<b>314</b>	161323	<b>401</b>	
Buff Black (Dry)	161325	<b>146</b>	161327	<b>206</b>	161328	<b>254</b>	161329	<b>298</b>	161330	<b>314</b>	161331	<b>401</b>	

## Hog Hair Cushion Pads

Description	Part No.	List <b>A</b>
12" x 1" Round	161581	<b>\$6.59</b>
17" x 1" Round	161455	<b>11.12</b>
20" x 1" Round	161473	<b>14.68</b>
21" x 1" Round	161474	<b>16.48</b>
24" x 1" Round	161576	<b>23.00</b>
27" x 1" Round	161475	<b>32.00</b>

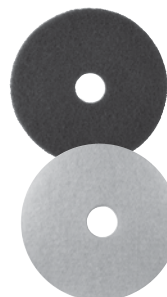

## Floor Maintenance Pads for Polished Concrete

Dimensions	Black Stripper	White Polish	List <b>A</b>
17" x 1" Round	A70003	A70004	<b>\$11.12</b>
20" x 1" Round	A70013	A70014	<b>14.68</b>
21" x 1" Round	A70015	A70016	<b>16.48</b>
24" x 1" Round	A70019	A70020	<b>23.00</b>
27" x 1" Round	A70017	A70018	<b>32.00</b>

Other pad sizes available. Call for info

# Diamond Pads / Chemicals / Pump-up Sprayers and Accessories



DOTS/LUX D/L-Series - 17" Resin <i>A</i>		
Grit	17" Part No.	List
1500	161340	\$271
3000	161341	271

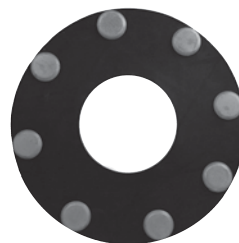

DOTS/Vacuum Brazed V-Series <i>A</i>		
Grit	17" Part No.	List
30	161613	\$697
50	161614	697
100	161615	697
200	161616	697



D - Series Semi-Metal						
Grit	17"		20"		21"	
	Part No.	List	Part No.	List	Part No.	List
30	161363	\$293	161364	\$682	161365	\$700
50	161369	293	161370	682	161371	700
100	161375	293	161376	682	161377	700
200	161381	293	161382	682	161383	700
400	161387	293	161388	682	161389	700
D Series Resin						
Grit	17"		20"		21"	
	Part No.	List	Part No.	List	Part No.	List
400	161393	\$271	161394	\$611	161395	\$630
800	161399	271	161400	611	161401	630
1800	161405	271	161406	611	161407	630
3000	161411	271	161412	611	161413	630

Cushion Pads	Part No.	List	<i>P</i>
Vortex velcro foam pad 7"	161433	\$41.00	
Vortex velcro foam pad 5"	161541	41.00	
Hog hair cushion pad-17" pad	161455	11.12	
Hog hair cushion pad-20" pad	161473	14.68	
Hog hair cushion pad-21" pad	161474	16.48	

Microfiber Mop and Mop Heads	Part No.	List	<i>P</i>
Microfiber Mop	160806	\$90	
Microfiber Mop Heads (red*) pkg of 10	160807	161	
Microfiber Mop Heads (blue*) pkg of 10	160808	161	
Microfiber Mop Heads (green*) pkg of 10	160809	161	
Microfiber Mop Heads (yellow*) pkg of 10	160810	161	

Colors are for customer identification purposes only



## Pump-up Sprayers for Decorative Concrete *E*

Description	Part No.	List
Sprayer for Acetone Dyes, 3.5 gal	160945	\$261
Sprayer for Acid Stains, 2 gal.	160946	114
Sprayer for Cure-N-Seal, 3.5 gal.	151470	185



## Daily Cleaner for Polished Concrete Floors Concentrated *A*

Description	Part No.	List
1 gallon*	161233	\$35
5 gallon	161234	165

\*Packaged 4 one gallon bottles per case



## DI-HARD Concrete Hardener/Densifier

Description	Sodium Formula		Lithium Formula	
	Part No.	List	Part No.	List
1 gallon bottle*	160940	\$35	161529	\$50
5 gallon bucket	160941	142	161530	221
55 gallon drum	160942	1,413		

\*Packaged 4 one gallon bottles per case



## Heavy-Duty Concentrated Degreaser for Polished Concrete Floors *A*

Description	Part No.	List
1 gallon*	161235	\$45
5 gallon	161236	210

\*Packaged 4 one gallon bottles per case



## DI-GARD Concrete Hardener/Sealer *A*

Description	Part No.	List
1 gallon bottle*	160943	\$108
5 gallon bucket	160944	489

\*Packaged 4 one gallon bottles per case

# Masonry Saws / Masonry Diamond Blades

## TEQ-CUT PRO V Masonry Saw

HORSEPOWER	1-1/2	1-1/2	2	3	5.5
MOTOR / ENGINE	Electric	Electric	Electric	Electric	Gas Honda
BLADE GUARD	14"	14"	14"	14"	14"
MODEL No.	MDV15D14	MLV15L14	MLV2L14	MLV3L14	MLV55H14
VOLTS	115	115/230	115/230	208/230	
AMPS	13	13/6.5	18-9	14.4	
WEIGHT	191 lbs	191 lbs	191 lbs	195 lbs	200 lbs
<b>PART No.</b>	<b>M10009</b>	<b>M10011</b>	<b>M10010</b>	<b>M10012</b>	<b>M10004</b>
<b>List</b>	<b>\$1,509</b>	<b>\$1,833</b>	<b>\$1,942</b>	<b>\$2,374</b>	<b>\$3,564</b>



TEQ-Cut Pro V Accessories	Item No.	P List
Folding Stand	120117	\$131.00
Water Pump - Little Giant	130002	106.00
Rip Guide	120151	13.39
Pigtail Cord - 20 Amp, Twist to 15 Amp	120009	43.00



Accessories	Part No.	P List
Folding Stand	120090	\$305

## Chopper

HORSEPOWER	1-3/4
MOTOR	115V/60 Hz
BLADE GUARD	14"
RPM	3500
Arbor Size	1"
Depth of Cut	5" (127mm)
Length of Cut	16" (406mm)
<b>PART No.</b>	<b>M10008</b>
<b>List E</b>	<b>\$1,185</b>

*Includes 14" B32 Slanted U-Slot Blade D43037*

## MASONRY DIAMOND BLADES

Material	C43 ARIX	C33 ARIX	C/A 34GD Guardian	B33 ARIX Silent	B35 ARIX Silent	B38 Silent	B32	B33 Silent Turbo	B28	C/A24 Combo	U13ST	U23ST	B22 Fire- Hawk	B41
Refractory														●
Hard Brick		●		●							●	●		
Brick	●	●	●	●	●		●	●		●	●	●	●	
Stone		●	●					●			●	●	●	
Clay tile			●							●	●		●	
Block/Pavers	●	●	●		●	●	●	●	●	●			●	

### C33AX

★★★ Super Premium  
Fastest Cut/Long Life Brick

Diameter & Width	Part No.	D List
12" x .125" x 1" 20mm DP	D11021	\$286
12" x .125" x 20mm DP	D11026	286
14" x .125" x 1" 20mm DP	D11022	319
14" x .125" x 20mm DP	D11027	319
16" x .125" x 1" 20mm DP	D11023	389
18" x .125" x 1" DP	D11024	427
20" x .145" x 1" DP	D11025	536



DRY/WET  
.393" seg. height

### C43AX

★★★★ PRO IV High Performance  
Fast Cut/Longest Life Brick/Block

Diameter & Width	Part No.	D List
12" x .125" x 1" 20mm DP	D10058	\$406
14" x .125" x 1" 20mm DP	D10053	444
14" x .125" x 20mm DP	D10069	444
16" x .125" x 1" 20mm DP	D10054	519
16" x .125" x 20mm DP	D10070	519
18" x .125" x 1" DP	D10055	536
20" x .145" x 1" DP	D10056	644

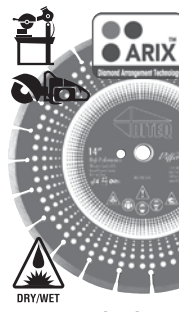

DRY/WET  
.393" seg. height

### B33 Silent Turbo

Diameter & Width	Part No.	D List
14" x .125" x 1" -20mm	D41023	\$427
20" x .145" x 1" -20mm	D44109	693



DRY/WET  
.393" segment height

# Masonry Diamond Blades

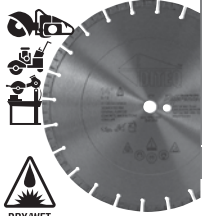

**U13 ST Segmented Turbo Blade**  
**★ General Purpose**  
*Fastest Cut/Good Life* *Brick/Hard Brick* *D*

Diameter & Width	Part No.	List
14" x .125" x 1"-20mm DP	D41030	\$125

DRY/WET  
 .472" seg. height



**B33AX, B35AX Silent Core**  
**★★★ Super Premium**

Diameter & Width	Brick/Block		List
	B33AX	B35AX	
14" x .125" x 1"	D44105	D44103	\$319
20" x .135" x 1"		D44104	812

DRY/WET



**U23 ST Segmented Turbo Blade**  
**★★ Premium General Purpose**  
*Fast Cut/Longest Life* *Brick/Block* *D*

Diameter & Width	Part No.	List
14" x .125" x 1"-20mm DP	D41004	\$265
16" x .125" x 1"-20mm DP	D41006	319

DRY/WET  
 .393 in. segment height

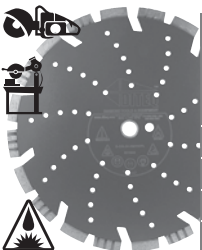

**C/A 24 Combo Dual**  
**★★ Premium**  
*Fast Cut/Long Life* *Brick/Block* *D*

Diameter & Width	Part No.	List
12" x .125" x 1" 20mm	D10201	\$238
14" x .125" x 1"-20mm	D11042	249
16" x .125" x 1"-20mm	D10202	308

DRY/WET  
 .590" seg height



**B32 Slanted U-Slot Segmented**  
**★★★ Super Premium** *Hard Brick/Block* *D*

Diameter & Width	Part No.	List
14" x .125" x 1"	D43037	\$211
20" x .135" x 1"	D43038	536

WET ONLY



**B22 Firehawk III Multi-Purpose Turbo Blade**  
**★★ Premium** *Fast Cut* *Brick/Block* *D*

Diameter & Width	Part No.	List
4" x .095" x 7/8 - 5/8"	D58013	\$38
4.5" x .095" x 7/8 - 5/8" flush	D58012	43
5" x .095" x 7/8 - 5/8" flush	D58011	48
6" x .095" x 7/8 - 5/8" flush	D58018	70
7" x .095" x 7/8 - 5/8" DM	D58014	92
10" x .110" x 7/8 - 5/8" DM	D58015	178
12" x .110" x 1" - 20mm DP	D58016	233
14" x .125" x 1" - 20mm DP	D58017	286

DRY/WET  
 4"-10" .393" seg height  
 12"-14".472" seg height



**B28 Segmented**  
**★★ Premium**

Diameter & Width	Block Part No.	List
14" x .125" x 1"	D43002	\$351
20" x .135" x 1"	D43004	427

DRY/WET  
 .393" segment height



**B38 Silent Core**  
**★★★ Super Premium** *Silent Core* *Block* *D*

Diameter & Width	Part No.	List
14" x .125" x 1"	D44101	\$319
20" x .135" x 1"	D44102	703

DRY/WET



**B41 Segmented**  
**★★★★ PRO IV** *Refractory* *D*

Diameter & Width	Part No.	List
14" x .125" x 1"	D43021	\$476
20" x .125" x 1"	D43023	536

DRY/WET  
 .335" seg. height

# Tuck Pointing / Crack Chasing Blades / TEQ-Grinders



## TP23 Segmented

★★ Premium		D	
Diameter & Width	Part No.	List	
4" x .250" x 7/8"-5/8"	D45001	\$38	
4.5" x .250" x 7/8"-5/8"	D45004	43	
5" x .250" x 7/8"-5/8"	D45007	55	
7" x .250" x DM-7/8"-5/8"	D45010	98	
4.5" x .375" x 7/8"-5/8"	D45020	65	
5" x .375" x 7/8"-5/8"	D45021	76	
7" x .375" x DM-7/8"-5/8"	D45022	103	

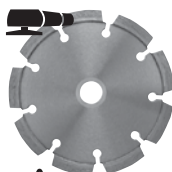

Laser Welded

## TP33 Segmented

★★★ Super Premium		D	
Diameter & Width	Part No.	List	
4" x .250" x 7/8"-5/8"	D45002	\$70	
4.5" x .250" x 7/8"-5/8"	D45005	81	
5" x .250" x 7/8"-5/8"	D45008	92	
7" x .250" x DM-7/8"-5/8"	D45011	151	



Laser Welded

## Double and Triple Segmented Tuckpoint Blades

Diameter & Width	TP23D Double ★★		TP33D Double ★★★ Super		TP33T Triple ★★★ Super		D
	Premium	List	Premium	List	Premium	List	
4" x .250" x 7/8"-5/8"	D45039	\$43					
4.5" x .250" x 7/8"-5/8"	D45040	55	D45032	\$87			
5" x .250" x 7/8"-5/8"	D45041	60	D45033	98			
7" x .250" x DM-7/8"-5/8"			D45034	163			
4.5" x .375" x 7/8"-5/8"					D45036	\$113	
5" x .375" x 7/8"-5/8"					D45037	135	



## CR C35 Beveled V-Crack Chaser

★★★ Super Premium		D	
Diameter & Width	Part No.	List	
4" x cont. type x 5/8"-11 thrd	D90001	\$211	
4 x .375" x 5/8-11	D90008	157	
4" x .375" x 7/8"-5/8"	D90002	146	
5" x .375" x 7/8"-5/8"	D90003	184	
7" x .375" x 7/8"-5/8"	D90004	298	
8" x .375" x 1" with DP	D90005	471	



## TG5V / TG6V TEQ-Grind

Outside Dia. of Disc	TG5V 5"	TG6V 6"
Watt/AMPs	750W/7.5 AMPS	1200W/12AMPS
No load speed	2800-10500/min	2800-10000/min
Spindle	5/8"-11 unc 7/8" arbor	5/8"-11 unc 7/8" arbor
Weight	3.7 lbs	6.3 lbs
<b>Part No.</b>	<b>G30005</b>	<b>G30006</b>
<b>List E</b>	<b>\$98</b>	<b>\$149</b>

## Accessories

	Part No.	List
Replacement Brushes for TG5V*	160109	\$3.24
Replacement Brushes for TG6V*	160110	\$4.33

\*Sold in sets of 2



Cut Buddie III shown on TG6V TEQ-Grind - see page 28 for product information



## ARIX Diamond Wire for Stone

Stone-Urethane		D	
Diameter & Width	Part No.	List	
C31 ARIX	D91019	\$351	
C30 ARIX	D91020	351	

Prices per meter length.

## Diamond Wire Accessories

	Part No.	List
Crimps (3/16" ID x 3/8" OD x 3/4" L)	151157	\$1.08
Crimps (3/16" ID x 3/8" OD x 1-1/8" L)	151304	4.33



<b>ARIX Diamond Wire for Stone</b>		
Stone-Urethane <span style="float: right;">D</span>		
Diameter & Width	Part No.	List
C31 ARIX	D91019	\$351
C30 ARIX	D91020	351

*Prices per meter length.*



Diamond Wire Accessories	Part No.	List <span style="float: right;">P</span>
Crimps (3/16" ID x 3/8" OD x 3/4" L)	151157	\$1.08
Crimps (3/16" ID x 3/8" OD x 1-1/8" L)	151304	4.33



<b>S52X ARIX Silent Core</b>				
20 mm / 25 mm Segment Height				
Stone & Granite Blade				
★★★★★ PRO V				
Diameter & Width	Part No.	List	Part No.	List <span style="float: right;">D</span>
14" x .125" x 60-50mm	D61111	\$489	D61121	\$630
16" x .125" x 60-50mm	D61112	590	D61122	721
18" x .135" x 60-50mm	D61113	705	D61123	903
20" x .135" x 60-50mm	D61114	966	D61124	1,017



<b>S21 Dish Turbo Convex Blade</b>		
★★ Premium <span style="float: right;">D</span>		
Diameter & Width	Part No.	List
5" x .110" x 7/8"-5/8"	D66031	\$132

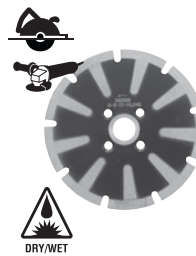

<b>S21 T-Segmented Blade</b>		
★★ Premium <span style="float: right;">D</span>		
Diameter & Width	Part No.	List
4.5" x .110" x 7/8"-5/8"	D62006	\$108
5" x .110" x 7/8"-5/8"	D62007	122

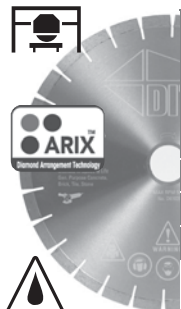

<b>S32X Silent Core 15 mm Segment</b>		
Height Stone & Granite Blade		
For Saws less than 10 hp		
★★★ Super Premium <span style="float: right;">D</span>		
Diameter & Width	Part No.	List
14" x .125" x 60-50mm	D61045	\$398
16" x .125" x 60-50mm	D61046	449

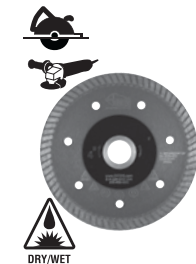

<b>S32 Raised Hub Turbo Blade</b>		
★★★ Super Premium <span style="float: right;">D</span>		
Diameter & Width	Part No.	List
4" x .060" x 7/8"-5/8"	D50032	\$42
4.5" x .060" x 7/8"-5/8"	D50033	60
5" x .060" x 7/8"-5/8"	D50034	78



<b>M22 Stone &amp; Hard Material Blade</b>		
★★ Premium <span style="float: right;">D</span>		
Diameter & Width	Part No.	List
8" x .110" x DM-7/8"-5/8"	D60001	\$148
10" x .110" x 1"	D60028	187
12" x .125" x 1-20mm	D60009	221
14" x .125" x 1-20mm	D60010	255
14" x .125" x 60-50mm	D60039	268
20" x .135" x 1"	D60027	512
20" x .135" x 1"*	D60037	710

\*Silent Core

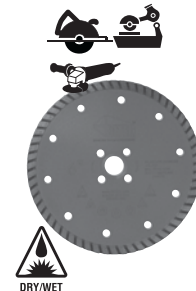

<b>S31 Turbo Blade</b>		
★★★ Super Premium <span style="float: right;">D</span>		
Diameter & Width	Part No.	List
4" x .085" x 7/8"-5/8" flush	D53021	\$34
4.5" x .085" x 7/8"-5/8" flush	D53022	36
5" x .085" x 7/8"-5/8" flush	D53020	45
6" x .085" x 7/8"-5/8"	D53023	60
7" x .085" x DM-7/8"-5/8"	D53024	78



<b>T42 Curly Que Blade</b>		
★★★★ PRO IV <span style="float: right;">D</span>		
Diameter & Width	Part No.	List
10" x .085" x 5/8"	D56006	\$135
14" x .095" x 1"-20mm	D56002	319

*Other sizes available. Please call for pricing and availability.*



<b>S42 Narrow Rim Turbo Blade</b>		
★★★★ PRO IV <span style="float: right;">D</span>		
Diameter & Width	Part No.	List
4" x .080" x 7/8"-5/8" flush	D53027	\$47
4.5" x .080" x 7/8"-5/8" flush	D53028	55
5" x .080" x 7/8"-5/8" flush	D53029	66
6" x .080" x 7/8"-5/8"	D53030	83
7" x .080" x DM-7/8"-5/8"	D53031	107



<b>Blade Adapters</b>		
Description	Part No.	List <span style="float: right;">P</span>
Flush Mount Adapter (Stainless)	130122	\$26.00
5/8" - 11F to 7/8" Arbor	130117	18.54

# Stone Fabrication Tools - Cutting

## DX-S Universal Segmented Blade

★ Economy, Fast Cut

Cured Concrete/Brick/Block



Diameter & Width	Part No.	List
4" x .080" x 7/8"-5/8"	D96205	\$22
4.5" x .080" x 7/8"-5/8"	D96206	25
5" x .080" x 7/8"-5/8"	D96220	30
6" x .080" x 7/8"-5/8"	D96221	42
7" x .080" x DM-7/8"-5/8"	D96207	47
8" x .085" x DM-7/8"-5/8"	D96222	60
9" x .095" x 7/8"-5/8"	D96223	66
10" x .095" x DM-7/8"-5/8"	D96208	83

## DX-T Wide Turbo Rim Blade

★ Economy, Fast Cut



Diameter & Width	Part No.	List
4" x .095" x 7/8"-5/8"	D96209	\$21
4.5" x .095" x 7/8"-5/8"	D96210	24
5" x .095" x 7/8"-5/8"	D96224	30
7" x .095" x DM-7/8"-5/8"	D96211	47
9" x .095" x 7/8"-5/8"	D96225	78
10" x .110" x 7/8"-5/8"	D96213	90

## S31V-S Vacuum Brazed Segmented Blade w/Side Protectors

★★★ Super Premium



Diameter & Width	Part No.	List
4.5" x .095" x 7/8"-5/8"	D66189	\$67
5" x .095" x 7/8"-5/8"	D66190	84
7" x .095" x DM-7/8"-5/8"	D66192	101

## M31V-S Vacuum Bond Blade

★★★ Super Premium

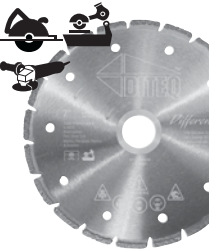

Diameter & Width	Part No.	List
4" x .095" x 7/8"-5/8"	D66011	\$47
4.5" x .095" x 7/8"-5/8"	D66012	66
5" x .095" x 7/8"-5/8"	D66013	69
7" x .095" x 7/8"-5/8"	D66015	90

## T23 Laser Cut Spider Continuous Rim

★★ Premium



Diameter & Width	Part No.	List
4" x .060" x 5/8"	D50053	\$27
4.5" x .060" x 5/8"	D50054	43
Wet Only		
Diameter & Width	Part No.	List
7" x .060" x 5/8"	D50040	\$60
8" x .060" x 5/8"	D50041	70
10" x .060" x 5/8"	D50042	103

## Sharpening Stone

Description	Part No.	List
Sharpening Stone	130009	\$6.49



.200" seg. height



## DX-C Continuous Rim Blade

★ Economy, Fast Cut



Diameter & Width	Part No.	List
4" x .060" x 5/8"	D96201	\$19.57
4.5" x .060" x 7/8"-5/8"	D96202	24
5" x .060" x 7/8"-5/8"	D96219	34
7" x .060" x 5/8"	D96203	47
10" x .060" x 5/8"	D96204	83

## T24 Continuous Rim

★★ Premium



Diameter & Width	Part No.	List
8" x .060" x 5/8"	D51009	\$65
10" x .080" x 5/8"	D51010	98
12" x .095" x 1"	D51011	146

## TG-32 Glass Tile Blade

★★★ Super Premium



Diameter & Width	Part No.	List
7" x .060" x 5/8"	D50056	\$58
10" x .060" x 5/8"	D50043	101

## S23 Thin Wall Crown Core Bits with 5/8" - 11 Threads

★★ Premium



Diameter	Part No.	List
3/8"	D31001	\$90
1/2"	D31002	93
5/8"	D31003	94
3/4"	D31004	98
7/8"	D31005	101
1"	D31006	110
1-1/8"	D31007	113
1-1/4"	D31008	134
1-3/8"	D31009	139
1-1/2"	D31010	143
1-5/8"	D31011	145
1-3/4"	D31012	148
1-7/8"	D31013	156
2"	D31014	173

## Threaded Adapters

Part No.	List
3/8" shank, 5/8"-11M	150217 \$30
1/2" shank, 5/8"-11M	150983 27

## S43AX Core Bit

★★★★ PRO IV



Diameter	Part No.	List
1-1/4" x 5/8-11th	D66215	\$108
1-3/8 x 5/8-11th	D66216	113
1-1/2" x 5/8-11th	D66217	119
1-3/4" x 5/8-11th	D66218	126
2" x 5/8-11th	D66219	142

3" drilling depth



(silver)  
3" drilling depth



S33 Laser Welded Segmented with Side Protectors - 5/8" -11 Threads		
★★★ Super Premium		
Diameter	Part No.	List
1-1/8"	D66203	\$96
1-1/4"	D66204	103
1-3/8"	D66205	108
1-1/2"	D66206	113
1-3/4"	D66208	119
2"	D66210	126
2-1/2"	D66211	142
3"	D66212	159
4"	D66213	176



(blue)  
3" drilling depth



S33 Laser Welded Segmented Type Core Bits with 5/8" -11 Thread				
★★★ Super Premium				
Diameter	Crown	Segmented	D	
	Part No.	List	Part No.	List
1/2"	D66134	\$68		
5/8"	D66135	71		
3/4"	D66136	73		
7/8"	D66137	77		
1"	D66032	80		
1-1/8"			D66119	\$85
1-1/4"			D66033	91
1-3/8"			D66034	96
1-1/2"			D66035	103
1-3/4"			D66036	108
2"			D66037	119
2-1/2"			D66118	131
3"			D66038	142
4"			D66138	159



2-3/4" drilling depth



S23V-C Vacuum Bond Core Bit		
★★ Premium		
Diameter	Part No.	List
1/4"	D66286	\$64
3/8"	D66287	66
1/2"	D66228	69
5/8"	D66229	80
7/8"	D66230	80
1"	D66231	80
1-1/8"	D66232	90
1-1/4"	D66233	90
1-1/2"	D66234	95
1-3/8"	D66235	98
2"	D66236	122

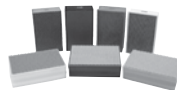

Hand Polishing Pads		
★★ Premium		
Grit	Part No.	List
50 Grit	130375	\$40
100 Grit	130376	40
200 Grit	130377	40
400 Grit	130378	40
800 Grit Resin	130380	28
1500 Grit Resin	130381	28
3000 Grit Resin	130382	28



Accessories		
Part No.	List	P
Replacement Brushes 130241	\$7.57	

\*Sold in sets of 2

TEQ-Shine Wet Polisher	
Outside Dia. of Disc	4"
Watt/AMPs	650W/6AMPs
No load speed	800-3600/min
Weight	6.17 lbs
Part No.	M00019
List E	\$232



Backer Pads (5/8"-11 threaded)		
Rubber	Part No.	List
3" Standard Flex	130119	\$13.39
4" Super Flex	130338	24.00
4" Standard Flex	130120	10.30
4" Rigid	130335	10.30
4" Extreme Flex	130510	24.00
5" Standard Flex	130121	36.00
7" Standard Flex	130520	44.00
Aluminum	Part No.	List
3" Aluminum	130522	24.00
4" Aluminum	130511	24.00
5" Aluminum	130512	39.00
7" Aluminum	130521	72.00

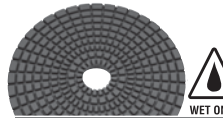

S33 Smooth Face Resin Filled Cup Wheels		
★★★ Super Premium		
Diameter & Width	Part No.	List
4" x coarse x 5/8"-11	D66063	\$152
4" x medium x 5/8"-11	D66065	152
4" x fine x 5/8"-11	D66089	152

## Wet Polishing Pads

Grit	★★ Premium		★★★ Super Premium			
	4"	4"	4"	5"	D	
	Part No.	List	Part No.	List	Part No.	List
50	D64082	\$14.42	D64010	\$22	D64019	\$40
100	D64083	14.42	D64011	22	D64020	40
200	D64084	14.42	D64012	22	D64021	40
400	D64085	14.42	D64013	22	D64022	40
800	D64086	14.42	D64014	22	D64023	40
1500	D64087	14.42	D64015	22	D64024	40
3000	D64088	14.42	D64016	22	D64025	40
10000DF (Blk)	D64089	21.00	D64017	25	D64026	45
10000DF (Wht)	D64090	21.00	D64018	25	D64027	45
Complete Set per box	D64091	126.00	D64070	181	D64028	336

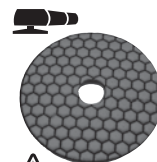

Dry Polishing Pads			
★★★ Super Premium			
Size	Grit	Part No.	List
4"	50	D64040	\$29
4"	100	D64041	29
4"	200	D64042	29
4"	400	D64043	29
4"	800	D64044	29
4"	1500	D64045	29
4"	3000	D64046	29
4"	10000DF (Blk)	D64047	29
4"	10000DF (Wht)	D64048	29
4"	Complete Set per box	D64071	250

# Terms and Conditions / Warranty

## To place orders:

Call 866-688-1032 or Fax: 877-220-4777

You will need the following items for Customer Service:

- Your purchase order number and/or name
- Company name and billing information
- Customer number
- Shipping address, if different from billing address
- Date needed
- Products desired and quantity

For detailed product information visit [www.DITEQ.com](http://www.DITEQ.com).

## Freight Policy

**Equipment:** Freight is paid (Ground Shipment) as one shipment to one location within the continental United States by the carrier of DITEQ's choice for three (3) pieces of equipment shipped of equal value.

**Diamond tools and/or Abrasives (with the exception of Carbide Cutters and Chemicals):** Freight is prepaid by the shipper and added to the invoice for orders less than \$400.00. Freight is paid (ground shipment) to one location within the continental United States by the carrier of DITEQ's choice for orders of \$400.00 or greater. Freight is prepaid by the shipper and added to the invoice on orders of carbide cutters only that are less than \$1,000.

**Parts and Chemicals:** Freight is prepaid by the shipper and added to the invoice.

**Orders of \$3,000 or greater in Diamond tools:** Freight is paid (ground shipment) to one location within continental United States by carrier of DITEQ's choice on the total order including all the additional items on the order.

Anything not meeting the exemptions above are Shipped FOB Factory.

We reserve the right to route all shipments via the carrier of DITEQ's choice.

Priority, Next Day or Two-day Service will be added to your invoice or billed collect.

Shipments requiring special handling or to a residence may incur additional charges.

## Terms and Conditions

**Minimum order:** For all finished product orders of less than \$50, a \$10 minimum order charge will be added. (shipping and tax excluded.)

Sales tax will be charged where applicable unless a tax exemption certificate is provided.

**Repairs:** Carefully package all returned items for repair and send with the following information on a packing slip:

- Your company name, address and phone number
- Original Invoice (warranty only)
- List of items for repair
- Returned Goods Authorization (RGA) number obtained from Customer Service
- Explanation of repair(s) needed

**Replacement/Refund:** All returned catalog items are subject to a 15% restocking fee. Returned for replacement or refund items should be in original cartons and accompanied by a packing slip with the following information:

- Contact customer service for a Returned Goods Authorization (RGA). (Merchandise cannot be accepted without this authorization.)
- List of items returned and reason(s) for return(s)
- Copy of original invoice(s). Merchandise receipt must be dated no longer than 12 months from date shipped.
- Ship merchandise prepaid to:  
DITEQ Corporation, 1250 NW Main Street, Lee's Summit, MO 64086

We reserve the right to change and/or modify products and part numbers. Images within this catalog may not reflect the most current product line.

Prices and specifications subject to change without notice.

© Copyright 2014 DITEQ Corporation. All rights reserved

## LIMITED WARRANTY FOR NEW DITEQ EQUIPMENT

**GENERAL PROVISIONS** — The warranties described below are provided by DITEQ Corporation ("DITEQ") to the original purchasers of new DITEQ Equipment from DITEQ or authorized DITEQ dealers. Under these warranties, DITEQ will repair or replace, at its option, any covered part which is found to be defective in material or workmanship during the applicable warranty term. Warranty service must be performed by DITEQ or a dealer or service center authorized by DITEQ to sell and/or service the type of product involved, which will use only new or remanufactured parts or components furnished by DITEQ. Warranty service will be performed without charge to the purchaser for parts. The purchaser will be responsible, however for any service call and/or labor, transportation and/or freight of product to and from DITEQ, the dealer's or service center's place of business, for any premium charged for overtime labor requested by the purchaser, and for any service and/or maintenance not directly related to any defect covered under the warranties below.

**WHAT IS WARRANTED** — All parts of any new DITEQ Equipment are warranted for the number of months specified below. Component manufacturers offer separate warranties and warranty terms as stated below. Warranty statements required by law covering engine emission-related parts and components are found in the engine operating manual delivered with the machine. Each warranty term begins on the date of product delivery to the purchaser.

27" Propane Burnisher	24 Months	Scarifier	12 Months
Baldor Motors	12 Months	Scarifier Drum	3 Months
Little Giant Pumps	12 Months	Shibuya Core Drills	24 Months
C-TEQ Saws	24 Months	Subaru Generator	36 Months
Chopper	12 Months	Subaru Robin Engines	36 Months
Dustless™ Vacuums	12 Months	Subaru water pumps	36 Months
Eaton Transmissions	12 Months	TEQ-Burnisher (Electric)	12 Months
G & P One Grinder / Polisher	24 Months	TEQ-Cut Pro V Masonry Saws	24 Months
G-TEQ Saws	24 Months	TG8 Grinder / Polisher	24 Months
Gast Vacuum Pumps	12 Months	TG12 Floor Grinder	24 Months
Honda Engines	36 Months	TG18 Floor Grinder	24 Months
Leeson Motors	12 Months	TEQ-Grind Hand Grinder	3 Months
Little Giant Pumps	12 Months	TEQ-Hammer II Hammer Drill	12 Months
LX-30 Grinder / Polisher	12 Months	TEQ-Swing	12 Months
Industrial Vacuum Systems	12 Months		
Rideable Scrubber	12 Months		

**WHAT IS NOT WARRANTED** — DITEQ IS NOT RESPONSIBLE FOR THE FOLLOWING:

(1) Used products; (2) Any product that has been modified in ways not approved by DITEQ; (3) Depreciation or damage caused by normal wear, lack of reasonable and proper maintenance, failure to follow operating instructions, misuse, lack of proper protection during storage, transporting or accident; (4) Normal maintenance parts such as belts, bearings, filters, wheels, cutters, etc. and service.

**SECURING WARRANTY SERVICE** — To secure warranty service, the purchaser must (1) report the product defect to DITEQ, an authorized dealer or an authorized service center and request repair within the applicable warranty term, (2) present evidence of the warranty start date, and (3) make the product available to DITEQ, the dealer or service center within a reasonable period of time.

**LIMITATIONS OF IMPLIED WARRANTIES AND OTHER REMEDIES** — To the extent permitted by law, neither DITEQ nor any company affiliated with it makes any warranties, representations or promises as to the quality, performance or freedom from defect of the equipment covered by this warranty.

**IMPLIED WARRANTIES OF MERCHANTABILITY AND FITNESS FOR A PARTICULAR PURPOSE, TO THE EXTENT APPLICABLE, SHALL BE LIMITED IN DURATION TO THE APPLICABLE PERIOD OF WARRANTY SET FORTH ON THIS PAGE. THE PURCHASER'S ONLY REMEDIES IN CONNECTION WITH THE BREACH OR PERFORMANCE OF ANY WARRANTY ON THE DITEQ EQUIPMENT ARE THOSE SET FORTH ON THIS PAGE. IN NO EVENT WILL THE DEALER, DITEQ OR ANY COMPANY AFFILIATED WITH DITEQ BE LIABLE FOR INCIDENTAL OR CONSEQUENTIAL DAMAGES.** (Note: Some states do not allow limitations on how long an implied warranty lasts or the exclusion or limitation of incidental or consequential damages so the above limitations and exclusions may not apply to you.) This warranty gives you specific legal rights, and you may also have other rights which vary from state to state. **NO DEALER WARRANTY-THE SELLING DEALER MAKES NO WARRANTY OF ITS OWN AND THE DEALER HAS NO AUTHORITY TO MAKE ANY REPRESENTATION OR PROMISE ON BEHALF OF DITEQ, OR TO MODIFY THE TERMS OR LIMITATIONS OF THIS WARRANTY IN ANY WAY.**

If further information is desired, please contact DITEQ.

# Cutting Speeds & Depths/Safety Warnings

## Diamond Blade Operating Speeds

Diameter	Recommended Operating Speed (RPM)*	Maximum Safe Speed (RPM)
4"	9,072	15,000
4-1/2"	8,063	13,300
5"	7,257	12,000
6"	6,048	10,185
7"	5,184	8,730
8"	4,536	7,640
9"	4,032	6,790
10"	3,629	6,110
12"	3,024	5,090
12" High Speed		6,300
14"	2,592	4,365
14" High Speed		5,460
16"	2,268	3,820
16" High Speed		4,725
18"	2,016	3,395
20"	1,814	3,055
22"	1,649	2,775
24"	1,512	2,545
26"	1,396	2,350
28"	1,296	2,180
30"	1,210	2,035
32"	1,134	1,910
36"	1,008	1,695
42"	864	1,455
48"	756	1,270
54"		1,130
60"		1,015

\*Based on 9,500 SFPM (Surface Feet Per Minute)

## Core Drill Operating Speeds

Diameter	Minimum Operating Speed (RPM)	Recommended Operating Speed (RPM)	Maximum Safe Speed (RPM)
1"	2400	3200	4000
2"	1200	1400	2000
3"	800	1000	1300
4"	600	900	1000
5"	500	700	800
6"	400	550	665
7"	350	450	600
8"	300	400	500
10"	250	300	400
12"	200	265	330
14"	170	225	285
16"	150	200	250
18"	130	175	220
20"	120	150	200
24"	100	130	165
30"	80	105	130

### Wet Bit Specifications

Bit Diameter	Core Travel
1" - 14"	14"
16" - 17"	20"
18" - 19"	22"
20" - 31"	24"
32" +	36"

THIS INFORMATION IS PROVIDED WITH ALL DIAMOND TOOL PACKAGING. PLEASE READ AND UNDERSTAND ALL INSTRUCTIONS AND WARNINGS PROVIDED WITH EACH TOOL.

Warning! THIS PRODUCT CONTAINS SOME OR ALL OF THE FOLLOWING:  
 aluminum oxide boron carbon chrome cobalt copper  
 diamond iron manganese molybdenum nickel  
 phosphorous silicon silicon carbide silver steel  
 tungsten tungsten carbide

This product as sold presents no hazard, although sawing, drilling, grinding and other construction activities may release small amounts of metal into the dust or slurry generated. Dust and slurry generated may contain other chemicals from materials cut. By example only, silica (SiO<sub>2</sub>) may be present in cement and other masonry products.

Precautionary steps, including appropriate respiratory protection and other control methods should be taken to ensure that worker exposure to dust not exceed appropriate PEL or TLV. (Reference OSHA 29 CFR Part 1910.1200).

Prolonged exposure to excessive amounts of dust can cause:

- Respiratory disease from inhalation; including pulmonary fibrosis;
- Skin irritation and rash from contact.

Nickel and certain compounds, which may be present in certain products, are considered carcinogenic by NTP and IARC. FOR ADDITIONAL INFORMATION REFER TO MSDS OR CONTACT THE MANUFACTURER.

Prop 65

Warning! The use of this product can cause the exposure to a chemical or chemicals known to the State of California to cause cancer and/or birth defects or other reproductive harm.

Prop 65

Warning! This product contains a chemical known to the State of California to cause cancer and/or birth defects or other reproductive harm.

Warning! IMPROPERLY USED GRINDING WHEELS, WIRE BRUSHES, BLADES AND BITS ARE DANGEROUS.

Warning! COMPLY WITH ANSI B7.1 AND OSHA 29 CFR 1900-1910 et al COVERING SPEED, SAFETY GUARDS, FLANGES, MOUNTING PROCEDURES, GENERAL OPERATING RULES, HANDLING, STORAGE, INSPECTION AND GENERAL MACHINE CONDITIONS.

## Maximum Blade Cutting Depth

Blade Diameter	Cutting Depth	Blade Diameter	Cutting Depth
<b>Concrete Saw Blades</b>		<b>Masonry Saw Blades</b>	
12"	3-5/8"	14"	5"
14"	4-5/8"	18"	7"
16"	5-5/8"	20"	8"
18"	6-5/8"	<b>Power Hand Saw Blades</b>	
20"	7-5/8"	6"	1-3/4"
24"	9-5/8"	7"	2-1/4"
26"	10-5/8"	8"	2-3/4"
30"	12-3/8"	9"	3-1/4"
36"	14-7/8"	10"	3-3/4"
42"	17-3/8"	<b>Tile Saw Blades</b>	
48"	19-7/8"	4"	1"
<b>High Speed Saw Blades</b>		4-1/2"	1-1/4"
12"	4"	5"	1-1/2"
14"	5"	7"	2-1/2"
16"	6"	8"	3"
<b>Wall Saw Blades</b>		10"	3-3/4"
18"	6-1/2"		
24"	9-1/2"		
30"	11-1/2"		
36"	14-1/2"		
42"	17-3/4"		
48"	20-3/4"		



1250 NW MAIN • LEE'S SUMMIT, MO 64086  
PHONE 866-688-1032 • FAX 877-220-4777